

CX21986 Hi Res USB Type-C Compliant Crystal-less Audio CODEC Datasheet

PN: 505-000826-01 Rev B

Description

The Synaptics® CX21986 is a highly-integrated, low-cost, crystal-free, USB audio CODEC solution that is optimized for USB Type-C headset applications.

The device features 24-bit stereo playback and record paths for music and voice communication applications. Sampling rates of up to 48 kHz are supported on the record path and up to 192 kHz at 16-bit or 96 kHz at 24-bit on the playback path. The CX21986 includes a digital five-band parametric Equalizer (EQ) for playback, a two-band EQ for recording, an adjustable microphone boost in 3 dB steps, and a stereo headphone driver.

The device uses a built-in, four-conductor headset jack that supports headphone/headset auto-detection and auto switching between CTIA and OMTP-style headsets without any external components.

The stereo playback path uses a capless headphone driver that eliminates the external BOM cost and PCB space of AC coupling capacitors, and supports 8, 16, 24, 32, 44.1, 48, 96, and 192 kHz sampling rates.

The CX21986 is compliant with industry specifications, including USB 2.0 Full Speed (FS), Windows HCK 2.1, as well as enterprise requirements for Skype for Business. The reference design requires a minimal PCB area and is ideal for USB headset and docking station designs.

Features

- 1.3 mA USB suspend current
- Hi-Res playback on USB, supporting a 96 Kbps sample rate with a 24-bit sample size
- Additional support for 192 Ksps USB playback sample rate with a 16-bit sample size
- Stereo record path for single-ended microphone input for 8, 16, 24, 32, 44.1, and 48 kHz sampling rates
- In-line four-button support on the microphone path that meets the *Android Wired Audio Headset Specification*
- DRC on the playback path
- Microphone boost settings: 0 dB–36 dB in 3 dB steps.
- High performance stereo audio ADC and DAC:
 - ADC: 97 dB
 - DAC: 103 dB
- Stereo capless headphone driver support for 16/32/10 K Ω loads. 87 dB THD driving to 32/10 K Ω loads
- Crystal free on-chip clock generation saves BOM cost
- Proprietary Synaptics Hum Noise Cancellation Technology for external speakers
- Digital Signal Processing (DSP):
 - DRC on playback path
 - Five-band digital equalizer for playback/recording
 - Microphone Automatic Gain Control (AGC)
- Analog pass through and side tone with volume control for line and MIC inputs.
- Supports wide range input supply from 3.0V to 5.5V
- Power management:
 - Internal Charge Pump (CP) for headphone and digital core logic
 - 1.8V analog supply generator
 - 3.3V supply for digital I/Os and external devices to support 90 mA drive capability.

- Digital MIC support
- Integrated 8Kbyte OTP memory
- Wake from either button push or headset plug-in
- 43-pin, 3.020 mm x 3.308 mm WLCSP package.

Confidential

Contents

	Description.....	1
	Features	1
1.	Functional Description	5
1.1.	System Block Diagram.....	6
1.2.	CX21986 CODEC Features.....	7
1.3.	Functional Applications	7
2.	Device Description	8
2.1.	USB Digital Audio	9
2.1.1.	USB Configuration Registers.....	9
2.1.2.	USB Volume Defaults	11
2.1.3.	USB Bus Power Requirement Register.....	14
2.1.4.	USB Terminal Types Registers	14
2.2.	Analog Inputs	17
2.2.1.	Analog Microphone Input to the ADC	17
2.3.	Output Signal Path.....	19
2.3.1.	Stereo Capless Headphone Driver	19
2.3.2.	Output Signal Path Volume Control Registers	20
2.4.	Digital Core	21
2.4.1.	ADC DSP.....	21
2.4.2.	DAC DSP	21
2.4.3.	Digital Signal Processing Registers	21
2.4.4.	Input EQ.....	22
2.4.5.	Microphone AGC and Activity Detector.....	23
2.4.6.	Output EQ.....	28
2.4.7.	Playback Path Dynamic Range Compression (DRC).....	32
2.4.8.	One-Time Programmable Memory.....	36
2.5.	External Accessory and Button Detection	37
2.5.1.	Multi-Standard Headset Support	37
2.5.2.	Jack Detect.....	38
2.5.3.	Microphone Button Detect (Android Wired Audio Headset Specification)	39
2.6.	Control Signals	41
2.6.1.	I ² C Configuration.....	41
2.6.2.	UART.....	42
2.6.3.	Button Matrix	42
2.6.4.	Read Key Value.....	43
3.	Power Management	44
3.1.	Charge Pump.....	44
3.2.	Reference Voltages.....	44
3.3.	LDOs	44
3.4.	Wake-Up Sources.....	44
4.	On-Chip Reference Clock Generation.....	45
5.	Synaptics Hum Noise Cancellation Technology.....	46
6.	Application Diagrams	47
6.1.	USB Type-C Docking Station and Audio Adapter	47
6.2.	USB Type-C Headset with Android Button Support	48
7.	Electrical Characteristics	49
8.	Pin Descriptions.....	52
8.1.	43-Pin WLCSP Hardware Interface Signals	52
8.2.	43-Pin WLCSP Pin Signals	53
8.3.	Pin Assignments.....	54
8.4.	Hardware Signal Definitions.....	55
9.	Power Consumption	58

10. Package Dimensions and Thermal Specifications 59

11. Ordering Information 61

12. Revision History 62

Confidential

1. Functional Description

The CX21986 minimizes the external BOM cost by removing the need for an external crystal and integrates a capless headphone driver that produces a full-range frequency response and eliminates AC coupling capacitors. The device integrates headset support with auto-detect and auto-switch between CTIA and OMTP-style headsets to eliminate all external BOM. The CX21986 can be powered by either 3.3V or 5V. The integrated LDO regulators provide clean micbias sources that ensure maximum performance. All internal analog circuitry uses differential signaling to guard against noise coupling from the GSM and TDMA radio frequencies. Current limiting circuitry that allows compliance with the USB inrush current requirement is also integrated. The CX21986 includes support for a PDM DMIC. A UART control interface is also available. Eleven GPIO pins are provided for peripheral connectivity. The CX21986 also includes an eight-button programmable keypad.

Confidential

1.1. System Block Diagram

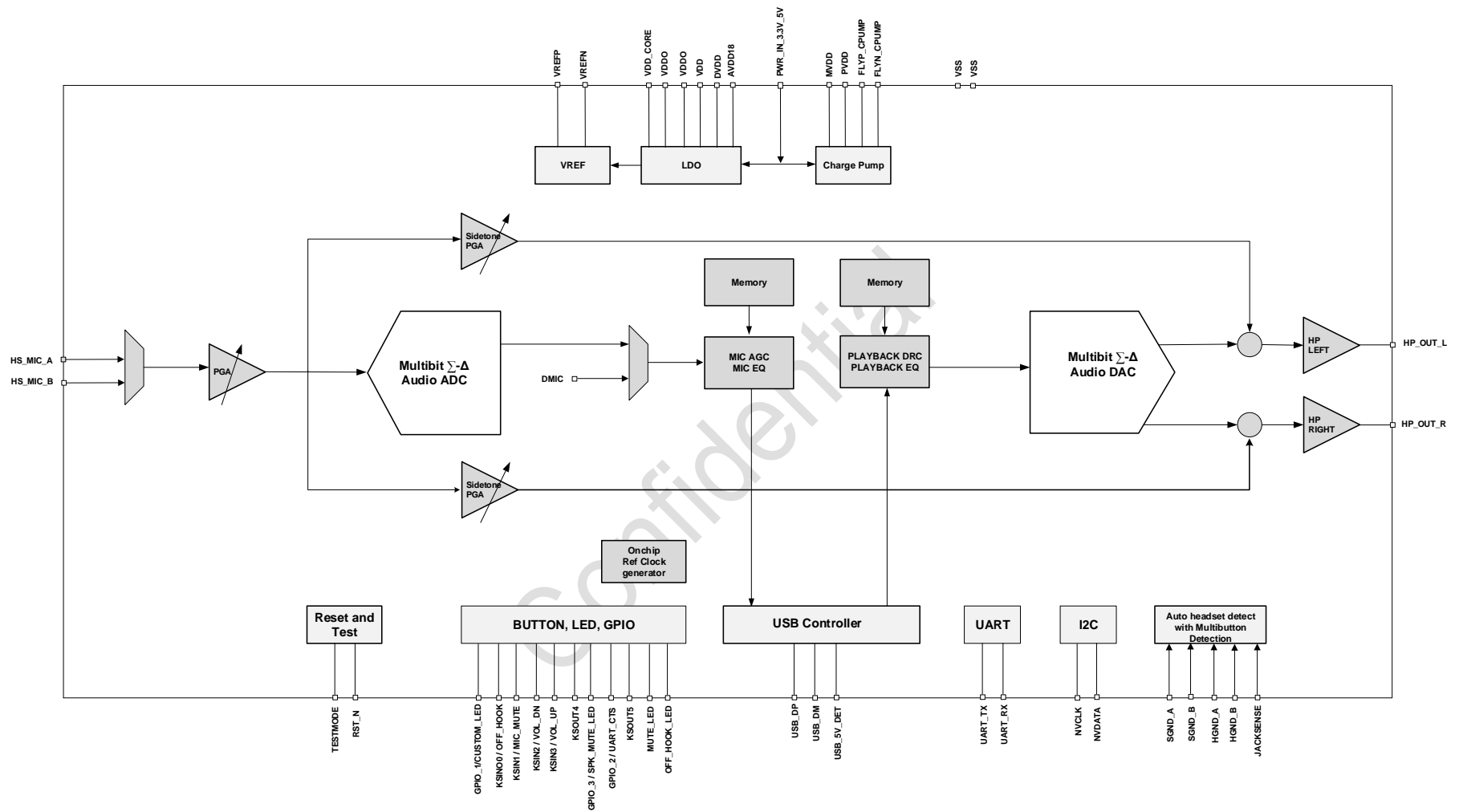

Figure 1. CX21986 system block diagram

1.2. CX21986 CODEC Features

- USB Type-C compliant stereo audio CODEC
- USB 2.0 full-speed compliant
- Crystal-free solution
- Available in a small WLCSP 3.020 mm x 3.308 mm package
- 1.3 mA USB suspend current
- Stereo record path supports a single-ended microphone input that supports 8kHz, 16kHz, 24kHz, 32kHz, 44.1kHz, and 48kHz sampling rates
- Stereo playback path with a capless headphone driver that eliminates the external BOM cost and PCB space of AC coupling capacitors, and supports 8kHz, 16kHz, 24kHz, 32kHz, 44.1kHz, 48kHz, 96kHz, and 192kHz sampling rates
- Built-in, four-conductor headset jack supports headphone/headset auto-detection, as well as auto switching between CTIA and OMTP-style headsets without any external components
- In-line four-button support on the microphone path that meets the *Android Wired Audio Headset Specification*
- DRC on the playback path
- Five-band digital EQ for playback and recording
- Microphone boost settings of 0 dB to 36 dB, in 3 dB steps.
- Internal 3.3V LDO can supply 90 mA for external circuitry.

1.3. Functional Applications

- USB Type-C headset
- USB Type-C docking station
- USB gaming headset

2. Device Description

In this section, details of the following items are discussed:

- CODEC
- Each audio interface
- Each control interface
- Each processing block
- Buttons
- LEDs
- GPIOs
- Detection circuits

The available processing in the CX21986 consists of:

- Two-band record EQ
- Five-band playback EQ
- AGC on the record path
- DRC on the playback path

The CX21986 has 11 GPIOs that can be used for custom button and LED behavior or other customer defined functions. The CX21986 integrates circuitry that can be used to detect:

- When an external jack has been plugged in
- When the output load has been plugged into the headphone port
- The type of headset used (standard versus OMTP)

The CX21986 also supports multi-button detection on the microphone signal, as defined by the *Android Wired Audio Headset Specification*.

2.1. USB Digital Audio

The CX21986 is a USB 2.0, full-speed compliant device. Volume settings, terminal types, and some additional customization are available, as detailed in the following sections.

2.1.1. USB Configuration Registers

The host options in this section are meant to be compiled time options and are set with a firmware patch residing in an external EEPROM. The options listed in this section should not be changed during run time. These RAM register locations are meant for debugging and informational purposes only.

Table 1. Host options 0x004D

Bit	Register Field Name	Register Description	Reset
7:5	Host [7:4]	Reserved	0x00
4	Host [4]	Enables mono/stereo HP detection	0x0
3	Host [3]	<ul style="list-style-type: none"> • 1 = Use the SENSE pin to detect four buttons. The buttons are mapped to same as KSOUT5 (see 0x65–0x68), and KSOUT5 can be freed to another function • 0 = Sense pins are used to detect normal jack sense 	0x0
2	Host [2]	<ul style="list-style-type: none"> • 1 = Use HS microphone • 0 = Use standard stereo microphones 	0x0
1	Host [1]	<ul style="list-style-type: none"> • 1 = USB mono microphone • 0 = USB stereo microphones 	0x0
0	Host[0]	Keypad scanning disable: <ul style="list-style-type: none"> • 0 = Scan full keypad • 1 = Scan only KSOUT5 and KSOUT4 	0x0

Table 2. Host1 location 0x004F

Bit	Register Field Name	Register Description	Reset
7	Host1 [7]	HID has telephony: <ul style="list-style-type: none"> • 1 = HID descriptor has a telephony page • 0 = HID descriptor does not have a telephone page 	0
6	Host1 [6]	USB remote wake-up: <ul style="list-style-type: none"> • 0 = Device is not capable of a remote wake-up • 1 = Device is capable of a remote wake-up 	1
5	Host1 [5]	USB-powered: <ul style="list-style-type: none"> • 1 = USB bus-powered—USB enumerates the requesting power base on USBPower[7:0] • 0 = USB self-powered—USB enumerates the requesting Oma from the bus 	1
4	Host1 [4]	USB line-in—if Host1[4] = 1. When this bit is set, the USB enumerates with a line input terminal, volume feature unit, and mixer that allows the line input to be routed to the speaker.	0
3	Host1 [3]	USB TX only—if Host1[3] = 1. When this bit is set, the USB enumerates with only the TX path exposed, which makes the USB look like a speaker only.	0
2	Host1 [2]	USB RX only—if Host1[2] = 1. When this bit is set, the USB enumerates with only the RX path exposed, which makes the USB look like a microphone only.	0
1	Host1 [1]	USB local volume—if Host1[0] = 0: <ul style="list-style-type: none"> • 1 = Button volume control is done locally and no HID information is transmitted • 0 = Button volume information is set to the USB using the HID if enumerated 	0
0	Host1 [0]	Use the volume infinity knob: <ul style="list-style-type: none"> • 1 = Use the Volume knob • 0 = Use the Volume buttons 	0

2.1.2. USB Volume Defaults

The defaults listed in this section control how the USB volume control blocks enumerate. The blocks control the minimum, maximum, and default volume settings exposed on the USB. All the following values are in Q8.8 format with a range for 5 dB to -74 dB.

Table 3. Speaker volume minimum low 0x0060

Bit	Register Field Name	Register Description	Reset
7:0	SpkVolumeMinL [7:0]	Speaker volume minimum—0x0500 to 0xB600 default 0xCE00 (-50 dB).	0x00

Table 4. Speaker volume minimum high 0x0061

Bit	Register Field Name	Register Description	Reset
7:0	SpkVolumeMinH [7:0]	Speaker volume minimum—0x0500 to 0xB600 default 0xCE00 (-50 dB).	0xCE

Table 5. Speaker volume maximum low 0x0062

Bit	Register Field Name	Register Description	Reset
7:0	SpkVolumeMaxL [7:0]	Speaker volume maximum—0x0500 to 0xB600 default 0x0500 (0 dB).	0x00

Table 6. Speaker volume maximum high 0x0063

Bit	Register Field Name	Register Description	Reset
7:0	SpkVolumeMaxH [7:0]	Speaker volume maximum—0x0500 to 0xB600 default 0x0000 (0 dB).	0x00

Table 7. Speaker volume resolution low 0x0064

Bit	Register Field Name	Register Description	Reset
7:0	SpkVolumeResL [7:0]	Speaker volume resolution—0x0000 to 0x7FFF default 0x0100 (1 dB).	0x00

Table 8. Speaker volume resolution high 0x0065

Bit	Register Field Name	Register Description	Reset
7:0	SpkVolumeResH [7:0]	Speaker volume resolution—0x0000 to 0x7FFF default 0x0100 (1 dB).	0x01

Table 9. Speaker volume default low 0x0066

Bit	Register Field Name	Register Description	Reset
7:0	SpkVolumeDefL [7:0]	Speaker volume default—0x0500 to 0xB600 default 0xFB00 (0 dB).	0x00

Table 10. Speaker volume default high 0x0067

Bit	Register Field Name	Register Description	Reset
7:0	SpkVolumeDefH [7:0]	Speaker volume default—0x0500 to 0xB600 default 0xFB00 (0 dB).	0x00

Table 11. Microphone volume minimum low 0x0070

Bit	Register Field Name	Register Description	Reset
7:0	MicVolumeMinL [7:0]	Microphone volume minimum—0x0500 to 0xB600 default 0xE200 (-30 dB).	0x00

Table 12. Microphone volume minimum high 0x0071

Bit	Register Field Name	Register Description	Reset
7:0	MicVolumeMinH[7:0]	Microphone volume minimum—0x0500 to 0xB600 default 0xE200 (-30 dB).	0xE2

Table 13. Microphone volume maximum low 0x0072

Bit	Register Field Name	Register Description	Reset
7:0	MicVolumeMaxL[7:0]	Microphone volume maximum—0x0500 to 0xB600 default 0x0500 (5 dB).	0x00

Table 14. Microphone volume maximum high 0x0073

Bit	Register Field Name	Register Description	Reset
7:0	MicVolumeMaxH[7:0]	Microphone volume maximum—0x0500 to 0xB600 default 0x0000 (0 dB).	0x00

Table 15. Microphone volume resolution low 0x0074

Bit	Register Field Name	Register Description	Reset
7:0	MicVolumeResL[7:0]	Microphone volume resolution—0x0000 to 0x7FFF default 0x0100 (1 dB).	0x00

Table 16. Microphone volume resolution high 0x0075

Bit	Register Field Name	Register Description	Reset
7:0	MicVolumeResH[7:0]	Microphone volume resolution—0x0000 to 0x7FFF default 0x0100 (1 dB).	0x01

Table 17. Microphone volume default low 0x0076

Bit	Register Field Name	Register Description	Reset
7:0	MicVolumeDefL [7:0]	Microphone volume default—0x0500 to 0xB600 default 0x0000 (0 dB).	0x00

Table 18. Microphone volume default high 0x0077

Bit	Register Field Name	Register Description	Reset
7:0	MicVolumeDefH [7:0]	Microphone volume default—0x0500 to 0xB600 default 0x0000 (0 dB).	0x00

Table 19. Sidetone volume minimum low 0x0078

Bit	Register Field Name	Register Description	Reset
7:0	SideToneMinL [7:0]	Sidetone volume minimum—0x0000 to 0xC700 default 0xC700 (-57 dB).	0x00

Table 20. Sidetone volume minimum high 0x0079

Bit	Register Field Name	Register Description	Reset
7:0	SideToneMinH[7:0]	Sidetone volume minimum—0x0000 to 0xC700 default 0xC700 (-57 dB).	0xC7

Table 21. Sidetone volume maximum low 0x007A

Bit	Register Field Name	Register Description	Reset
7:0	SideToneMaxL[7:0]	Sidetone volume maximum—0x0000 to 0xC700 default 0x0000 (0 dB).	0x00

Table 22. Sidetone volume maximum high 0x007B

Bit	Register Field Name	Register Description	Reset
7:0	SideToneMaxH[7:0]	Sidetone volume maximum—0x0000 to 0xC700 default 0x0000 (0 dB).	0x00

Table 23. Sidetone volume resolution low 0x007C

Bit	Register Field Name	Register Description	Reset
7:0	SideToneResL[7:0]	Sidetone volume resolution—0x0000 to 0x7FFF default 0x0180 (1.5 dB).	0x80

Table 24. Sidetone volume resolution high 0x007D

Bit	Register Field Name	Register Description	Reset
7:0	SideToneResH[7:0]	Sidetone volume resolution—0x0000 to 0x7FFF default 0x0080 (1.5 dB).	0x01

Table 25. Sidetone volume default low 0x007E

Bit	Register Field Name	Register Description	Reset
7:0	SideToneDefL [7:0]	Sidetone volume default—0x0000 to 0xC700 default 0xE200 (-30 dB).	0x00

Table 26. Sidetone volume default high 0x007F

Bit	Register Field Name	Register Description	Reset
7:0	SideToneDefH [7:0]	Sidetone volume default—0x0000 to 0xC700 default 0xE200 (-30 dB).	0xE2

2.1.3. USB Bus Power Requirement Register

The USB bus power requirement is enumerated to the host when the device is bus powered Host1 [5]=1. The power is specified in mA/2 per the USB specification.

Table 27. USB power 0x0088

Bit	Register Field Name	Register Description	Reset
7:0	USBPower [7:0]	USB bus power requirement is specified in mA/2—0x01 to 0xFF default 0x32 (100 mA).	0x32

2.1.4. USB Terminal Types Registers

The CX21986 allows for customization of the terminal types of the playback and record endpoints, which can be defined as headset, headphone, communications speaker, etc. The options in this section allow the designer to modify the USB terminal type. For a complete list of terminal types, refer to the *USB Device Class Definition for Terminal Types Release 1.0 Guide*.

When defining headset terminal types, it may be necessary to associate the microphone and speaker terminal IDs:

- Microphone terminal ID = ID 1
- Speaker terminal ID = ID 6
- Chat speaker = ID 8

Table 28. Speaker terminal type low 0x0089

Bit	Register Field Name	Register Description	Reset
7:0	SpkTypeL [7:0]	Speaker terminal type—default 0x301 speaker Common types: <ul style="list-style-type: none"> • 0x301 = Speaker • 0x302 = Headphone • 0x306 = Communication speaker • 0x401 = Handset • 0x402 = Headset 	0x01

Table 29. Speaker terminal type high 0x008A

Bit	Register Field Name	Register Description	Reset
7:0	SpkTypeH [7:0]	Speaker terminal type—default 0x301 speaker Common types: <ul style="list-style-type: none"> • 0x301 = Speaker • 0x302 = Headphone • 0x306 = Communication speaker • 0x401 = Handset • 0x402 = Headset 	0x03

Table 30. Speaker association 0x008B

Bit	Register Field Name	Register Description	Reset
7:0	SpkTypeH [7:0]	Speaker association: <ul style="list-style-type: none"> • 0x00 = None • 0x01 = Microphone 	0x00

Table 31. Reserved 0x008C–008E

Bit	Register Field Name	Register Description	Reset
Reserved	—	Reserved	—

Table 32. Microphone terminal type low 0x008F

Bit	Register Field Name	Register Description	Reset
7:0	MicTypeL [7:0]	Microphone terminal type—default 0x201 microphone <ul style="list-style-type: none"> • Common types: • 0x201 = Microphone • 0x206 = Processing microphone array • 0x401 = Handset • 0x402 = Headset 	0x01

Table 33. Microphone terminal type high 0x0090

Bit	Register Field Name	Register Description	Reset
7:0	MicTypeH [7:0]	Microphone terminal type—default 0x201 microphone <ul style="list-style-type: none"> • Common types: • 0x201 = Microphone • 0x206 = Processing microphone array • 0x401 = Handset • 0x402 = Headset 	0x02

Table 34. Microphone association 0x0091

Bit	Register Field Name	Register Description	Reset
7:0	MicTypeH [7:0]	Speaker association: <ul style="list-style-type: none"> • 0x00 = None • 0x06 = Microphone 	0x00

2.1.4.1. Volume Balance Control Registers

There are options to choose if the volume control is a single control applied to both left and right, or is an individual left right control for balance control.

Table 35. Volume balance control 0x0092

Bit	Register Field Name	Register Description	Reset
7:3	Reserved	Reserved	0x0
2	MicMasterVol[3]	Microphone balance control: <ul style="list-style-type: none"> • 0 = Balance Control • 1 = Master Volume 	0x1
1	Reserved	Reserved	0x0
0	SpkMasterVol [0]	Speaker balance control: <ul style="list-style-type: none"> • 0 = Balance Control • 1 = Master Volume 	0x0

Confidential

2.2. Analog Inputs

2.2.1. Analog Microphone Input to the ADC

The audio input signal path is designed to support single-ended microphone and line input signals. [Figure 2](#) provides suggested configurations for each case.

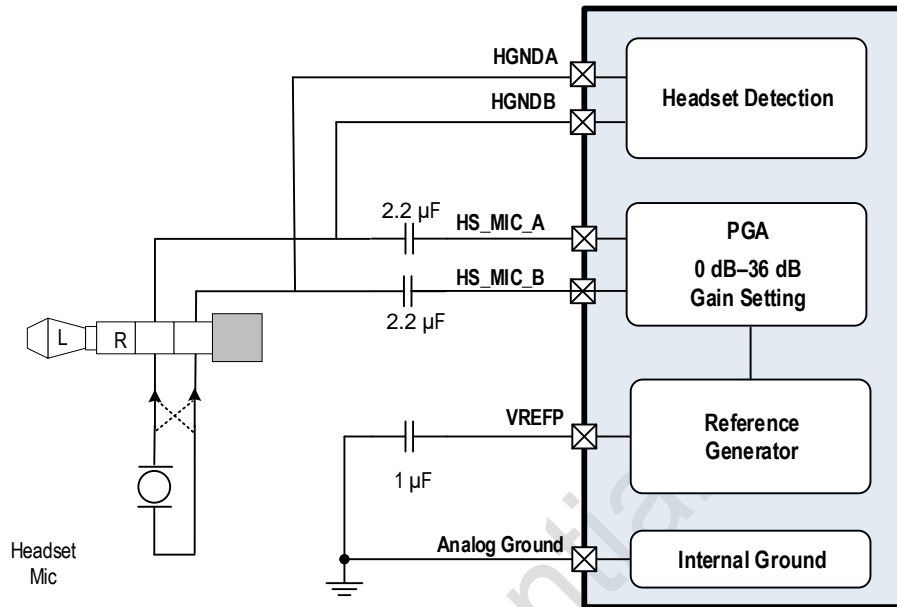

Figure 2. Headset micbiasing configuration

The microphone bias (micbias) circuit provides a bias voltage to a microphone connected to one of the microphones, or both depending on the selection. See [Table 112](#) for mic bias options.

2.2.1.1. Gain and Mute Registers for the Analog Microphone and Line Inputs

This section provides the gain and mute registers for the analog microphone and line inputs.

Table 36. Microphone gain left 0x100E

Bit	Register Field Name	Register Description	Reset
7:0	MICL [7:0]	This gain is in series with the USB line-in volume control. The microphone gain is in 1 db steps: <ul style="list-style-type: none"> • 0x05 = 5 dB • 0x04 = 4 dB ... • 0xB6 = -74 dB 	0x00

Table 37. Microphone gain right 0x100F

Bit	Register Field Name	Register Description	Reset
7:0	MICR [7:0]	This gain is in series with the USB line-in volume control. The microphone gain is in 1 db steps: <ul style="list-style-type: none"> • 0x05 = 5 dB • 0x04 = 4 dB ... • 0xB6 = -74 dB 	0x00

Table 38. Volume mutes 0x1012

Bit	Register Field Name	Register Description	Reset
7:4	Reserved	Reserved	0
3	Mute [3]	Left microphone mute: <ul style="list-style-type: none"> • 0 = Unmute • 1 = Mute 	0
2	Mute [2]	Right microphone mute: <ul style="list-style-type: none"> • 0 = Unmute • 1 = Mute 	0

2.3. Output Signal Path

2.3.1. Stereo Capless Headphone Driver

The CX21986 output signal path provides a stereo capless headphone driver that can drive loads as low as 16Ω . The nominal load is 32Ω and includes the ability to operate safely in open circuits with capacitive loads of up to 400 pF . A line-output mode is also provided where the headphone amplifier can conserve power by driving light loads such as a $10\text{ k}\Omega$ line input load.

The digital DAC headphone stereo path driver is a capless design that uses an output signal that is output referenced to ground. There are no AC coupling capacitors required for connecting to headphone loads.

The CX21986 output signal path consists of a 24-bit sigma delta DAC for high performance applications. The output signal path of the CX21986 is also designed for very low pop operation of less than -65 dB (A- Weighted).

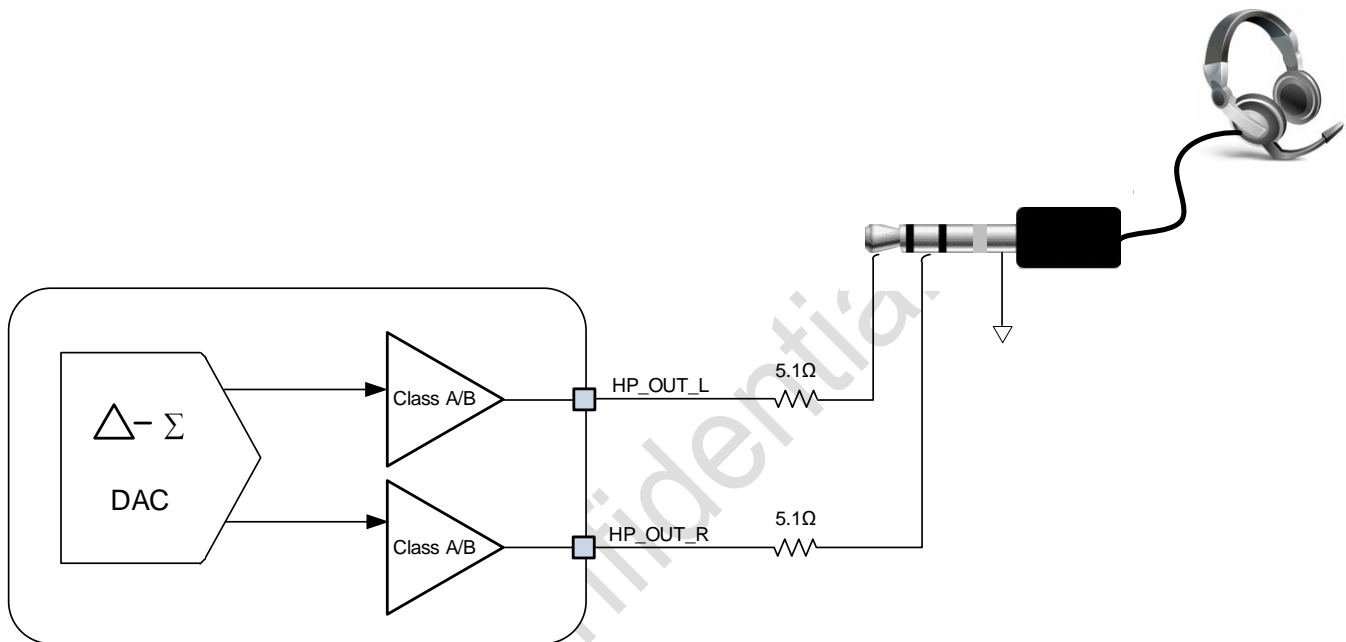

Figure 3. Output signal path diagram

2.3.2. Output Signal Path Volume Control Registers

Table 39. DAC1 left 0x100A

Bit	Register Field Name	Register Description	Reset
7:0	DACL [7:0]	<p>This gain is in series with the USB volume control.</p> <p>The DAC gain is in 1db steps:</p> <ul style="list-style-type: none"> • 0x05 = 5 dB • 0x04 = 4 dB ... • 0xB6 = -74 db 	0x05

Table 40. DAC2 right 0x100B

Bit	Register Field Name	Register Description	Reset
7:0	DACR [7:0]	<p>This gain is in series with the USB volume control.</p> <p>The DAC gain is in 1db steps:</p> <ul style="list-style-type: none"> • 0x05 = 5 dB • 0x04 = 4 dB ... • 0xB6 = -74 db 	0x05

Table 41. Volume mutes 0x1012

Bit	Register Field Name	Register Description	Reset
1	Mute [1]	<p>Left speaker mute:</p> <ul style="list-style-type: none"> • 0 = Unmute • 1 = Mute 	0
0	Mute [0]	<p>Right speaker mute:</p> <ul style="list-style-type: none"> • 0 = Unmute • 1 = Mute 	0

2.4. Digital Core

2.4.1. ADC DSP

A Digital Signal Processing (DSP) system, with an analog audio input signal in the range 0 kHz to –20 kHz, uses downsampling techniques to convert the analog single bit stream at a high rate to a digital code at a low rate.

A multistage decimator converts the output of a 3rd order delta-sigma from a single-bit stream at

12.288 MHz into 17 bit stream at (44.1 kHz/48 kHz/96 kHz/8 kHz/16 kHz/24 kHz/22.05 kHz/32 kHz). The ADC datapath consists of:

- 3 half bands – Decimation
- Polyphase SRC
- Programmable gain
- Sync filter

2.4.2. DAC DSP

A DSP system, with digital audio input signal in the range of 0 kHz to –20 kHz, uses oversampling techniques and a 3rd order delta-sigma modulator to convert the 16/24 bit digital signal at sampling frequencies 44.1 kHz/48 kHz/96 kHz/8 kHz/16 kHz/24 kHz/22.05 kHz/32 kHz into a multi-bit stream at a rate of 12.288 MHz.

The DAC datapath consists of:

- Equalizer and crossover
- Dynamic range compression logic
- 3 half bands – Interpolation
- Polyphase SRC
- Programmable gain
- Sigma delta modulation and scrambler

2.4.3. Digital Signal Processing Registers

Register 0x118C shows the processing options available in the CX21986.

Table 42. DSP processing enable register 0x118C

Bit	Register Field Name	Register Description	Reset
7	DSPEn1[7]	Reserved	0
6	DSPEn1 [6]	Reserved	0
5	DSPEn1 [5]	Side tone enable	1
4	DSPEn1 [4]	Microphone AGC enable. The AGC only works if the sample rate is 8 kHz or 16 kHz.	0
3	DSPEn1 [3]	Playback DRC enable	0
2	DSPEn1 [2]	Record path two-band EQ enable	0
1	DSPEn1 [1]	Playback path five-band EQ enable	0

Table 43. DSP processing enable register 0x118C

Bit	Register Field Name	Register Description	Reset
0	DSPEn1 [0]	NEWC. The act/process changes to the host API. This bit clears when the update is done. When this bit is set, the host should read this bit to verify that it has cleared before modifying any other API registers.	0

2.4.4. Input EQ

The record path EQ consists of two bands, and there is a profile for each supported record frequency. The EQ RXEQEna [2] = 1.

The implementation consists of two second-order IIRs in series in each channel. Each second-order IIR has the three b_0 , b_1 , and b_2 forward coefficients that operate on the input, and the two a_1 and a_2 feedback coefficients that operate on the output and a scaling factor G :

$$H(z) = (G \cdot b_0 + G \cdot b_1 \cdot z^{-1} + G \cdot b_2 \cdot z^{-2}) / (1 - G \cdot a_1 \cdot z^{-1} - G \cdot a_2 \cdot z^{-2}), y_n = G \cdot (a_1 \cdot y_{n-1} + a_2 \cdot y_{n-2} + b_0 \cdot x_n + b_1 \cdot x_{n-1} + b_2 \cdot x_{n-2}) \quad [1]$$

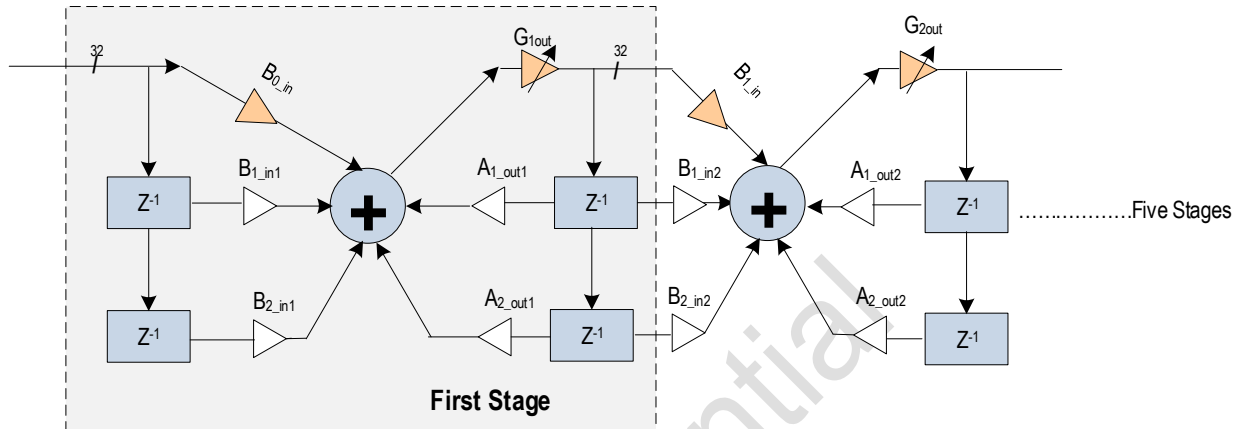

Figure 4. EQ block diagram

Record Path EQ 8K

- EQ Band1 8K coefficient from address 0x112D–0x1137
- EQ Band2 8K coefficient from address 0x1138–0x1142

Record Path EQ 16K

- EQ Band1 16K coefficient from address 0x1143–0x114D
- EQ Band2 16K coefficient from address 0x114E–0x1158

Record Path EQ 32K

- EQ Band1 32K coefficient from address 0x1159–0x1163
- EQ Band2 32K coefficient from address 0x1164–0x116E

Record Path EQ 44.1K

- EQ Band1 44.1K coefficient from address 0x116F–0x1179
- EQ Band2 44.1K coefficient from address 0x117A–0x1184

Record Path EQ 48K

- EQ Band1 48K coefficient from address 0x1185–0x118F
- EQ Band2 48K coefficient from address 0x1190–0x119A

2.4.5. Microphone AGC and Activity Detector

The microphone AGC function can be broken down in to three sections:

- Activity detector
- Gain control
- Dynamic Range Compression (DRC)

Because the microphone AGC is intended for voice conversation and both channels have similar energy characteristics, the gain is only calculated on one channel and applied to both channels. The microphone AGC block supports both 16 kHz and 8 kHz samples (16-bit). The AGC curve is shown in this section.

Table 44. AD_DC_REJECT_POLE—0x11A7

Bit	Name	Default	R/W	Register Description
7:0	AD_DC_REJECT_POLE	8'hC0	R/W	POLE location for the datIn DC rejection IIR filter. $Z = AD_DC_REJECT_POLE/2^{15}$ The AD_DC_REJECT_POLE is 16 bits: <ul style="list-style-type: none"> • Bit 15 = Fixed at 0 for a positive only value • Bits 14–7 = Programmed through this register • Bits 6–0 = Fixed at 0

Table 45. AD_BETA_VOICE_SHFT—0x11A8

Bit	Name	Default	R/W	Register Description
7:4	Reserved	4'h0	R	Reserved
3:0	AD_BETA_VOICE_SHFT	4'h2	R/W	PowerIn fast averaging IIR filter beta coefficient. $PowerIn = PowerIn \cdot (1 - Beta/2^{15}) + FrameEnergy \cdot (Beta/2^{15})$ The range is 0–15 for a beta range of $2^{(15-0)}$ to $2^{(15-15)}$. The default beta is $2^{(15-2)}$ or 2^{13} .

Table 46. AD_BETA_NOISE_SHFT—0x11A9

Bit	Name	Default	R/W	Register Description
7:4	Reserved	4'h0	R	Reserved
3:0	AD_BETA_NOISE_SHFT	4'hB	R/W	PowerNoiseAvg slow averaging IIR filter beta coefficient. $PowerNoise = PowerNoise \cdot (1 - Beta/2^{15}) + FrameEnergy \cdot (Beta/2^{15})$ The range is 0–15 for a beta range of $2^{(15-0)}$ to $2^{(15-15)}$. The default beta is $2^{(15-11)}$ or 2^4 .

Table 47. AD_TEST_GAIN—0x11AA

Bit	Name	Default	R/W	Register Description
7:4	Reserved	4'h0	R	Reserved
3:0	AD_TEST_GAIN	4'h0	R/W	Test only register. Left shift of the datIn input signal to the AGC module by the number of specified bits.

Table 48. AD_RELEASE_DELAY MSB—0x11AB

Bit	Name	Default	R/W	Register Description
7:0	AD_DC_REJECT_POLE	8'hC0	R/W	POLE location for the datIn DC rejection IIR filter. $Z = AD_DC_REJECT_POLE/2^{15}$ The AD_DC_REJECT_POLE is 16 bits: <ul style="list-style-type: none"> • Bit 15 = Fixed at 0 for a positive only value • Bits 14–7 = Programmed through this register • Bits 6–0 = Fixed at 0

Table 49. AD_RELEASE_DELAY LSB—0x11AC

Bit	Name	Default	R/W	Register Description
7:0	AD_RELEASE_DELAY	8'h2C	R/W	In units of ms and used to program the period of time passed before allowing the noise power to increase.

Table 50. AD_POWERIN_INITVAL MSB—0x11AD

Bit	Name	Default	R/W	Register Description
7:0	AD_POWERIN_INITVAL	8'h0A	R/W	PowerIn—Voice power register is 32 bits. This register programs the reset value for bits 23 to 30. Bit 31 is fixed at 0.

Table 51. AD_POWERIN_INITVAL LSB—0x11AE

Bit	Name	Default	R/W	Register Description
7:0	AD_POWERIN_INITVAL	8'h0A	R/W	PowerIn—Voice power register is 32 bits. This register programs the reset value for bits 15 to 22. Bits 0 to 14 are fixed at 0.

Table 52. AD_MIN_SNR MSB—0x11AF

Bit	Name	Default	R/W	Register Description
7:0	AD_MIN_SNR	8'hE9	R/W	AD_MIN_SNR[15:8]: Minimum SNR in dB.

Table 53. AD_MIN_SNR LSB—0x11B0

Bit	Name	Default	R/W	Register Description
7:0	AD_MIN_SNR	8'h00	R/W	AD_MIN_SNR[7:0]: Minimum SNR in dB.

Table 54. AGC_VOLUME_RAMP_STEP—0x11B1

Bit	Name	Default	R/W	Register Description
7:0	AD_POWERNOISE_MULT	8'h8	R/W	AGC volume ramp step size in dB. The default is 8 = round(0.03 • 2 ⁸).

Table 55. AD_POWERNOISE_INITVAL MSB—0x11B2

Bit	Name	Default	R/W	Register Description
7:0	AD_POWERNOISE_INITVAL	8'hE9	R/W	Power noise—Noise power register is 16 bits. This register programs the reset value for bits 8 to 15.

Table 56. AD_POWERNOISE_INITVAL LSB—0x11B3

Bit	Name	Default	R/W	Register Description
7:0	AD_POWERNOISE_INITVAL	8'h00	R/W	Power noise—Noise power register is 16 bits. This register programs the reset value for bits 0 to 7.

Table 57. AD_MIN_THRESH MSB—0x11B4

Bit	Name	Default	R/W	Register Description
7:0	AD_MIN_THRESH	8'hC1	R/W	AD_MIN_THRESH [15:8] offset for the decision threshold to prevent false detection of voice when the signal is low. This value is 16-bit unsigned.

Table 58. AD_MIN_THRESH LSB—0x11B5

Bit	Name	Default	R/W	Register Description
7:0	AD_MIN_THRESH	8'h00	R/W	AD_MIN_THRESH [7:0] offset for the decision threshold to prevent false detection of voice when the signal is low. This value is 16-bit unsigned.

Table 59. AD_ON2OFF_DELAY_BLOCKS—0x11B6

Bits	Name	Default	R/W	Description
7:5	Reserved	3'h0	R	Reserved
4:0	AD_ON2OFF_DELAY_BLOCKS	5'h14	R/W	On to off delay in number of blocks.

Table 60. AGC_UPDATE_BKS—0x11B7

Bit	Name	Default	R/W	Register Description
7:5	Reserved	3'h0	R	Reserved
4:0	AGC_UPDATE_BKS	5'ha	R/W	Number of blocks of sample used to calculate a new gain.

Table 61. AGC_ENERGY_THRESH_LO MSB—0x11B8

Bit	Name	Default	R/W	Register Description
7:0	AGC_ENERGY_THRESH_LO	8'hE8	R/W	Threshold for a decision if the gain must be increased. Only the upper 8 bits of the etmp value is compared. The default value is $-24 \cdot 2^8$.

Table 62. AGC_ENERGY_THRESH_HI MSB—0x11B9

Bit	Name	Default	R/W	Register Description
7:0	AGC_ENERGY_THRESH_HI	8'hF7	R/W	Threshold for a decision if the gain must be decreased. Only the upper 8 bits of the etmp value is compared. The default value is $-9 \cdot 2^8$.

Table 63. AGC_STABILITY_BLOCKS—0x11BA

Bit	Name	Default	R/W	Register Description
7	Reserved	1'h0	R	Reserved
6:0	AGC_STABILITY_BLOCKS	7'd60	R/W	Value compared to the stability counter to ensure that the gain does not oscillate (increase/decrease) too rapidly.

Table 64. AGC_STEP_UP—0x11BB

Bit	Name	Default	R/W	Register Description
7:0	AGC_STEP_UP	8'd18	R/W	The amount that the gain is to be increased.

Table 65. AGC_STEP_DOW MSB—0x11BC

Bit	Name	Default	R/W	Register Description
7:0	AGC_STEP_DOWN	8'hEE	R/W	The amount that the gain is to be decreased.

Table 66. AGC_STAB_CNT_POS_INC—0x11BD

Bit	Name	Default	R/W	Register Description
7:4	Reserved	4'h0	R	Reserved
3:0	AGC_STAB_CNT_POS_INC	4'h1	R/W	The amount that the stability counter is to be increased. The range is 0 to 15

Table 67. AGC_STAB_CNT_NEG_INC—0x11BE

Bit	Name	Default	R/W	Register Description
3:0	AGC_STAB_CNT_NEG_INC	4'hC	R/W	The amount that the stability counter is to be decreased. The range is 0 to -16.

Table 68. DRC_RELEASE_DELAY MSB 0x11BF

Bit	Name	Default	R/W	Register Description
7:0	DRC_RELEASE_DELAY	8'h40	R/W	In units of ms and used to program the time passed before MaxAbsIn can be decreased to a lower value if the input level is not increasing. The hysteresis for adjusting the gain upward.

Table 69. DRC_GAIN_STEP_SLOW 0x11C0

Bit	Name	Default	R/W	Register Description
7:0	DRC_GAIN_STEP_SLOW	8'h10	R/W	Coefficient for the MaxAbsIn IIR filters. The DRC_GAIN_STEP_SLOW coefficient is 10-bit unsigned. This register programs bits 2 to 9, while bits 0 to 1 are fixed at 0.

Table 70. DRC_GAIN_STEP_FAST 0x11C1

Bit	Name	Default	R/W	Register Description
7:0	DRC_GAIN_STEP_FAST	8'h40	R/W	Coefficient for the target gain filters. The DRC_GAIN_STEP_FAST coefficient is 15-bit unsigned. This register programs bits 7 to 14, while bits 0 to 6 are fixed at 0.

Table 71. DRC_MAX_LIN_OUT 0x11C2

Bit	Name	Default	R/W	Register Description
7:0	DRC_MAX_LIN_OUT	8'hE0	R/W	Max linear output of the DRC. The DRC_MAX_LIN_OUT is 16-bit signed. This register programs bits 4 to 11. Bits 12 to 15 are fixed at 4'hF, and bits 0 to 3 are fixed at 4'h0.

Table 72. DRC_GAIN_SHIFT 0x11C3

Bit	Name	Default	R/W	Register Description
2:0	DRC_GAIN_SHIFT	3'h5	R/W	Gain is in Q6.10/Q6.26 format, 5-bit scale down from Q1.15/Q1.31.

Table 73. DRC_MAXABS_INITVAL 0x11C4

Bit	Name	Default	R/W	Register Description
7:0	DRC_MAXABS_INITVAL	8'h3A	R/W	Initial value for MaxAbsIn is: <ul style="list-style-type: none"> • $\text{MaxAbsIn} = \text{DRC_MAXABS_INITVAL} \cdot 2^{24}$ Initial value for MaxAbsPre is: <ul style="list-style-type: none"> • $\text{MaxAbsPre} = \text{DRC_MAXABS_INITVAL} \cdot 2^8$ The range is -32 to 31.

Table 74. AGC_GAIN_INITVAL 0x11C5

Bit	Name	Default	R/W	Register Description
7:0	AGC_GAIN_INITVAL	8'h00	R/W	Initial value for the AGC gainctrl gain output to micdrc.

Table 75. DRC_OUTPUT_LIMIT 0x11C6

Bit	Name	Default	R/W	Register Description
7:0	DRC_OUTPUT_LIMIT	8'h00	R/W	DRC output limit. This register programs the 8 MSB bit of the 16-bit signed value.

Table 76. AGC_CLIPPING_THRESH 0x11C7

Bit	Name	Default	R/W	Register Description
7:0	AGC_CLIPPING_THRESH	8'hF9	R/W	AGC clipping threshold. The default value is $-7 \cdot 2^8$.

2.4.6. Output EQ

The implementation consists of five second-order IIRs in series in each channel. Each second-order IIR has the three b_0 , b_1 and b_2 forward coefficients operating on the input, and the two a_1 and a_2 feedback coefficients operating on the output and a scaling factor G :

$$H(z) = (G \cdot b_0 + G \cdot b_1 \cdot z^{-1} + G \cdot b_2 \cdot z^{-2}) / (1 - G \cdot a_1 \cdot z^{-1} - G \cdot a_2 \cdot z^{-2}). y_n = G \cdot (a_1 \cdot y_{n-1} + a_2 \cdot y_{n-2} + b_0 \cdot x_n + b_1 \cdot x_{n-1} + b_2 \cdot x_{n-2}) \quad [2]$$

Because the coefficients are programmable, there is full flexibility of the filter type, band-frequency, Q factor, and gain. The only limitation is that the band's frequency usually cannot be below 60Hz (at a 48 kHz sampling rate), which results from the fixed point resolution of 16 bits per coefficient.

Because the IIR implements a graphic EQ and the values are changed on a user command, the update is slow.

The graphic EQ tuning of each band's parameters (filter-type, frequency, Q factor, and gain) is done through a software tool, which internally calculates the fixed point coefficients and scaling that correspond with each set of parameters, and sends the coefficients/scaling to the device.

For more details, see the EQ block diagram in [Figure 4](#).

2.4.6.1. Playback EQ 8K API Registers

This section lists the playback EQ API registers.

Note: Each set of registers applies to a specific sample rate.

Table 77. EQ Band1 8k coefficient B0 low 0x1018

Bit	Register Field Name	Register Description	Reset
7:0	TXBand18KB0L	CODEC IIR B0 feed forward coefficient low byte.	0x00

Table 78. EQ Band1 8K coefficient B0 high 0x1019

Bit	Register Field Name	Register Description	Reset
7:0	TXBand18KB0H	CODEC IIR B0 feed forward coefficient high byte.	0x40

Table 79. EQ Band1 8K coefficient B1 low 0x101A

Bit	Register Field Name	Register Description	Reset
7:0	TXBand18KB1L	CODEC IIR B1 feed forward coefficient low byte.	0x00

Table 80. EQ Band1 8K coefficient B1 high 0x101B

Bit	Register Field Name	Register Description	Reset
7:0	TXBand18KB1H	CODEC IIR B1 feed forward coefficient high byte.	0x00

Table 81. EQ Band1 8K coefficient B2 low 0x101C

Bit	Register Field Name	Register Description	Reset
7:0	TXBand18KB2L	CODEC IIR B2 feed forward coefficient low byte.	0x00

Table 82. EQ Band1 8K coefficient B2 high 0x101D

Bit	Register Field Name	Register Description	Reset
7:0	TXBand18KB2H	CODEC IIR B2 feed forward coefficient high byte.	0x00

Table 83. EQ Band1 8K coefficient A0 low 0x101E

Bit	Register Field Name	Register Description	Reset
7:0	TXBand18KA0L	CODEC IIR A0 feed forward coefficient low byte.	0x00

Table 84. EQ Band1 8K coefficient A0 high 0x101F

Bit	Register Field Name	Register Description	Reset
7:0	TXBand18KA0H	CODEC IIR A0 feed forward coefficient high byte.	0x00

Table 85. EQ Band1 8K coefficient A1 low 0x1020

Bit	Register Field Name	Register Description	Reset
7:0	TXBand18KA1L	CODEC IIR A1 feed forward coefficient low byte.	0x00

Table 86. EQ Band1 8K coefficient A1 high 0x1021

Bit	Register Field Name	Register Description	Reset
7:0	TXBand18KA1H	CODEC IIR A1 feed forward coefficient high byte.	0x00

Table 87. EQ Band1 8K gain 0x1022

Bit	Register Field Name	Register Description	Reset
7:0	TXBand18KGain	CODEC IIR coefficient gain: <ul style="list-style-type: none"> • 0 = -12dB, range [-0.25, 0.25) • 1 = -6dB, range [-0.5, 0.5) • 2 = 0dB, range [-1,1) • 3 = 6dB, range [-2,2) • 4 = 12dB, range [-4,4) • 5 = 18dB, range [-8,8) 	0x00

EQ Band2 8K Coefficient from Address 0x1023–0x102D

- B0 coefficient 0x4000
- B1 coefficient 0x0000
- B2 coefficient 0x0000
- A0 coefficient 0x0000
- A1 coefficient 0x0000
- Gain 0x03

EQ Band3 8K Coefficient from Address 0x102E–0x1038

- B0 coefficient 0x4000
- B1 coefficient 0x0000
- B2 coefficient 0x0000
- A0 coefficient 0x0000
- A1 coefficient 0x 0000
- Gain 0x03

EQ Band4 8K Coefficient from Address 0x1039–0x1043

- B0 coefficient 0x4000
- B1 coefficient 0x 0000
- B2 coefficient 0x0000
- A0 coefficient 0x0000
- A1 coefficient 0x 0000
- Gain 0x03

EQ Band5 8K Coefficient from Address 0x1044–0x104E

- B0 coefficient 0x4000
- B1 coefficient 0x0000
- B2 coefficient 0x0000
- A0 coefficient 0x0000
- A1 coefficient 0x0000
- Gain 0x03

EQ 16K

- EQ Band1 16K coefficient from address 0x104F–0x1059
- EQ Band2 16K coefficient from address 0x105A–0x1064
- EQ Band3 16K coefficient from address 0x1065–0x106F
- EQ Band4 16K coefficient from address 0x1070–0x107A
- EQ Band5 16K coefficient from address 0x107B–0x1085

EQ 32K

- EQ Band1 32K coefficient from address 0x1086–0x1090
- EQ Band2 32K coefficient from address 0x1091–0x109B
- EQ Band3 32K coefficient from address 0x109C–0x10A6
- EQ Band4 32K coefficient from address 0x10A7– 0x10B1
- EQ Band5 32K coefficient from address 0x10B2–0x10BC

EQ 44.1K

- EQ Band1 44.1K coefficient from address 0x10BD–0x10C7
- EQ Band2 44.1K coefficient from address 0x10C8–0x10D2
- EQ Band3 44.1K coefficient from address 0x10D3–0x10DD
- EQ Band4 44.1K coefficient from address 0x10DE– 0x10E8
- EQ Band5 44.1K coefficient from address 0x10E9–0x10F3

EQ 48K

- EQ Band1 48K coefficient from address 0x10F4–0x10FE
- EQ Band2 48K coefficient from address 0x10FF–0x1109
- EQ Band3 48K coefficient from address 0x110A–0x1014
- EQ Band4 48K coefficient from address 0x1115– 0x111F
- EQ Band5 48K coefficient from address 0x1120–0x112C

EQ Gains

The EQ gains are the gains applied at the end of the EQ stage whenever the EQ is enabled. The dB gain can be calculated using this formula:

$$20 \cdot \text{Log}_{10}(X / 0x1000) = \text{dB} \quad [3]$$

Min 0x0000

Max 0x7FFF

Default 0x1000 (0dB)

Table 88. EQ gain low 0x112B

Bit	Register Field Name	Register Description	Reset
7:0	EQ_GAINL	Gain of the final output stage of the EQ chain.	0x00

Table 89. EQ gain high 0x112C

Bit	Register Field Name	Register Description	Reset
7:0	EQ_GAINH	Gain of final output stage of the EQ chain.	0x10

2.4.7. Playback Path Dynamic Range Compression (DRC)

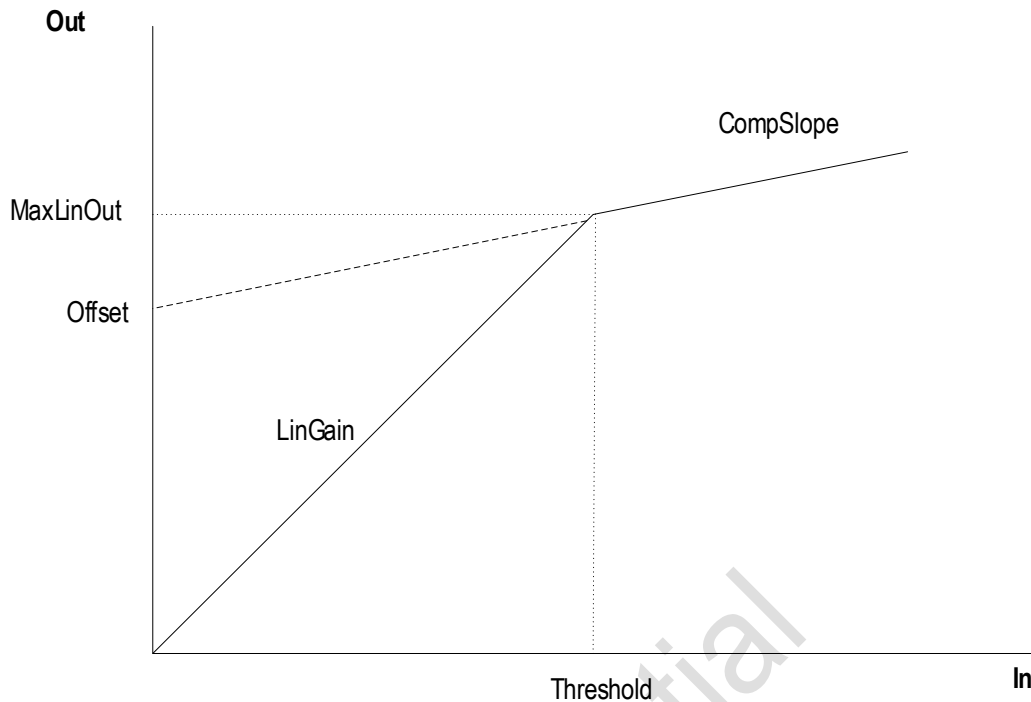

Figure 5. DRC curve

The DRC allows signal level to be boosted while preventing clipping distortion. The DRC behaves as a signal-dependent amplifier, with the amplifier's gain determined according to a gain function. This function has a programmable threshold, or "knee." The function provides a linear gain below the threshold, also known as a "boost," and above which there is compression. The compression slope is set to 0, which is referred to as "infinite compression."

The DRC has fast response in case of an "attack," which is defined as any event of a peak in the input signal becoming greater than the latest estimation of the input magnitude. If the signal goes into the high region (above threshold), fast reduction of the gain is needed to prevent audible distortion due to clipping. The rate of response to attack events is controlled by the attack time parameter.

The DRC has a slower response, known as "release," when all peaks in the input signal stay below the latest estimation of the input magnitude during a certain interval. The slower response includes some delay followed by a smooth change of the gain and its purpose is to prevent amplitude modulation (or amplitude jitter). If the signal has been in the high region, the gain is slowly increased during the release. The release rate is controlled by the release time parameter.

The DRC integrates into the volume control as if the volume is applied at the input to the DRC. This integration allows the DRC not to reduce the gain for a low volume setting, where there is no risk of clipping.

The programmable parameters for DRC are:

- **Attack rate** = Allows one of eight attack times to be set: 4 ms, 8 ms, 16 ms, 32 ms, 64 ms, 128 ms, 256 ms, and 512 ms.
- **Release rate threshold** = In the range -30 to 30 dB. If the input peaks are below this threshold, then the slow release is selected—otherwise the fast release is selected.
- **Slow release rate** = Allows 1 of 16 release time settings (the same supported values as for the attack rate) plus 1024 ms, 2048 ms, 4096 ms, 8192 ms, 16384 ms, 32768 ms, 65536 ms, and 131072 ms.
- **Slow release delay** = Allows 1 of 16 delay value settings before the release starts. All powers of 2 from 1 ms to 32768 ms (1, 2, 4, 8 ... 16384, 32768).
- **Fast release rate** = Allows 1 of 16 release time settings, same supported values as for slow release rate.
- **Fast release delay** = Allows 1 of 16 release time settings (the same supported values as for the slow release delay).
- **Boost** = Ranging from 0 dB to 30 dB.
- **Threshold** = Ranging from -16 dB to 0 dB, specified for the output peak level. The threshold for the input peak level equals to the threshold for the output peaks minus the boost.
- **Maximal gain** = Allows limiting the maximal gain to one of eight values: 0 dB, 6 dB, 12 dB, 18 dB, 24 dB, 30 dB, 36 dB, and 42 dB.

Table 90. SPKR DRC CTRL1 0x119B

Bit	Register Field Name	Default	Register Description
7:4	SPKR_DRC_RELEASE_UPDATE_STEP	0xA	Used to program the gain step required to release the gain slowly when the signal is in the linear region.
3:1	SPKR_DRC_ATTACK_UPDATE_STEP	0x2	Used to program the gain step required to compress the incoming signal in the compression region.
0	Reserved	0	Reserved

Table 91. SPKR DRC CTRL2 0x119C

Bit	Register Field Name	Default	Register Description
7:4	Reserved	0	Reserved
3:0	SPKR_DRC_RELEASE_DELAY	0xA	In units of ms and used to program the period of time passed before MaxAbsIn can be decreased to a lower value if the input level is not increasing. The hysteresis for adjusting the gain upward. Internally, the four bits are used as: RELEASE_DELAY = $2^{SPKR_DRC_RELEASE_DELAY_LOG2}$

Table 92. SPKR DRC CTRL3 0x119D

Bit	Register Field Name	Default	Register Description
7:4	SPKR_DRC_FAST_RELEASE_DELAY	0x6	SPKR_DRC_FAST_RELEASE_DELAY_LOG2—Used to program the release delay value. This is used to update the release delay value to make a quick transition in the gain value. Internally to SPKR DRC block: FAST_RELEASE_DELAY = $2^{SPKR_DRC_FAST_RELEASE_DELAY_LOG2}$
3:0	SPKR_DRC_FAST_UPDATE_STEP	0x5	Used to program the step value. This will be used to quickly update the MAXABS IN value.

Table 93. SPKR DRC CTRL3 0x119D

Bit	Register Field Name	Default	Register Description
7:6	Reserved	0	Reserved
5:0	SPKR_DRC_BOOST	0x0	<p>The gain value initially set for DRC. The 6 bits are split internally to the SPKR DRC block as:</p> <ul style="list-style-type: none"> • DRC_BOOST_MANT[3:0] = SPKR_DRC_BOOST[3:0] • DRC_BOOST_EXP[1:0] = SPKR_DRC_BOOST[5:4] <p>The final BOOST is:</p> <ul style="list-style-type: none"> • BOOST[15:10 + EXP] = 0 • BOOST[9 + EXP:6 + EXP] = MANT • BOOST[5 + EXP:0] = 0

Table 94. SPKR DRC CTRL5 0x119F

Bit	Register Field Name	Default	Register Description
7:6	Reserved	0	Reserved
5:0	SPKR_DRC_MAX_LIN_OUT	0x0	<p>Used to set threshold and limit values. The 6 bits are split internally to the SPKR DRC block as:</p> <ul style="list-style-type: none"> • DRC_MAX_LIN_OUT_MANT[3:0] = SPKR_DRC_MAX_LIN_OUT[3:0] • DRC_MAX_LIN_OUT_EXP[1:0] = SPKR_DRC_MAX_LIN_OUT[5:4] <p>The final MAX_LIN_OUT is:</p> <ul style="list-style-type: none"> • MAX_LIN_OUT[15:10 + EXP] = Sign extend MSB of MANT • MAX_LIN_OUT[9 + EXP:6 + EXP] = MANT • MAX_LIN_OUT[5 + EXP:0] = 0

Table 95. SPKR DRC CTRL6 0x11A0

Bit	Register Field Name	Default	Register Description
7:6	Reserved	0	Reserved
5:0	SPKR_DRC_MAX_LIN_OUT	0x0	<p>Determines the balance RAMP STEP size. The 6 bits are split internally to the SPKR DRC block as:</p> <ul style="list-style-type: none"> • DRC_BALNCE_RAMP_MANT[3:0] = SPKR_DRC_BALANCE_RAMP_STEP[3:0] • DRC_BALANCE_RAMP_EXP[2:0] = SPKR_DRC_BALANCE_RAMP_STEP[6:4] <p>The final BALANCE RAMP STEP is:</p> <ul style="list-style-type: none"> • BALANCE_RAMP_STEP[15:7 + EXP] = 0 • BALANCE_RAMP_STEP[6 + EXP:3 + EXP] = MANT • BALANCE_RAMP_STEP[2 + EXP:0] = 0

Table 96. SPKR DRC CTRL7 0x11A1

Bit	Register Field Name	Default	Register Description
7:6	Reserved	0	Reserved
5:3	SPKR_DRC_VOLUME_RAMP_STEP_SHIFT_SELECT	0x4	Selects the step and shift size for volume ramping. Internal calculations are: $VOLUME_RAMP_STEP = 2 \cdot (2^{SPKR_DRC_VOLUME_RAMP_STEP_SHIFT_SELECT})$ $VOLUME_RAMP_MAX_SHIFT = 10 - SPKR_DRC_VOLUME_RAMP_STx4EP_SHIFT_SELECT$
2:0	SPKR_DRC_GAIN_SHIFT	0x4	Gain shift value

Table 97. SPKR DRC CTRL8 0x11A2

Bit	Register Field Name	Default	Register Description
7:6	Reserved	0	Reserved
5:0	SPKR_DRCRELEASE_RATE_TH	0	Threshold for deciding whether to use slow release (with RELEASE_UPDATE_STEP) or fast release (with TRANSIENT_UPDATE_STEP). The 6 bits are split internally to SPKR DRC block as: <ul style="list-style-type: none"> DRC_RELEASE_RATE_TH_MANT[3:0] = SPKR_DRC_RELEASE_RATE_TH[3:0] DRC_MAX_RELEASE_RATE_TH_EXP[1:0] = SPKR_DRC_RELEASE_RATE_TH[5:4] The final RELEASE_RATE_TH is: <ul style="list-style-type: none"> RELEASE_RATE_TH[15:10 + EXP] = sign extend MSB of MANT RELEASE_RATE_TH[9 + EXP:6 + EXP] = MANT RELEASE_RATE_TH[5 + EXP:0] = 0

Table 98. DRC Gain Control 0x11A3

Bit	Register Field Name	Default	Register Description
7:1	Reserved	—	Reserved
0	INT_DRC_GAIN_CTRL	1'b0	Enables the interpolator gain and DRC gain that come from the register. The gain for: <ul style="list-style-type: none"> Interpolator comes from 0xF15 and 0xF16 DRC comes from 0xF31 and 0xF32

Table 99. DAC 1 DRC Volume/Gain 0x11A4

Bit	Type	Default	Name	Description
7	R	0	R	Reserved
6:0	R/W	4A	DAC 1 DRC Volume	Programmable gain stage in digital: <ul style="list-style-type: none"> 0x4F = 5 dB 0x4E = 4 dB 0x4D = 3 dB 0x4C = 2 dB ... 0x3 = -71 dB 0x2 = -72 dB 0x1 = -73 dB 0x0 = -74 dB

Table 100. DAC 2 DRC Volume/Gain 0x11A5

Bit	Type	Default	Name	Description
7	R	0	R	Reserved
6:0	R/W	4A	DAC 2 DRC Volume	Programmable gain stage in digital: <ul style="list-style-type: none"> • 0x4F = 5 dB • 0x4E = 4 dB • 0x4D = 3 dB • 0x4C = 2 dB ... • 0x3 = -71 dB • 0x2 = -72 dB • 0x1 = -73 dB • 0x0 = -74 dB

Table 101. SPKR DRC Release Control 0x11A6

Bit	Type	Default	Name	Description
7:0	R/W	0	SPKR DRC RELEASE CONTROL	Programmable speaker DRC release control

2.4.8. One-Time Programmable Memory

The CX21986 CODEC can be configured and integrated within a design either by using an external EEPROM or the integrated OTP saving PCB area and cost.

The OTP is intended to store basic chip configurations and settings to optimize performance. A typical application of the OTP memory is to store product-specific customization of the standard firmware image.

The CX21986 device provides 8K Byte of One-Time-Programmable (OTP) memory. This memory is accessible by the on-chip CPU, and may be used for code or data storage.

While any location within the OTP memory may be written only once, the 8KB memory is sufficiently large enough to allow for 3 or 4 revisions of a typically sized data/code image. To program the OTP, a voltage of 6.0V must be provided to the CX21986 input power pin.

For use and configuration of OTP memory, consult the *CX21988 OTP Programming Procedure Application Note*.

2.5. External Accessory and Button Detection

2.5.1. Multi-Standard Headset Support

Most headsets use four-terminal 3.5mm plugs to support stereo audio playback and mono microphone. Tip and Ring1 are always the left and right playback signals, but two standards exist for the location of the ground and microphone signals.

One type of headset has the ground signal on Ring2, and the microphone signal on the sleeve, which is referred to as the CTIA standard. The other type is referred to as OMTP, and has the ground signal on the sleeve and the microphone signal on Ring2.

Either of the four-terminal jack configurations are also backward-compatible with the normal three-terminal headphone plug. In this case, the sleeve of the headphone plug is twice as large and connects to both the Ring2 and sleeve terminals of the jack.

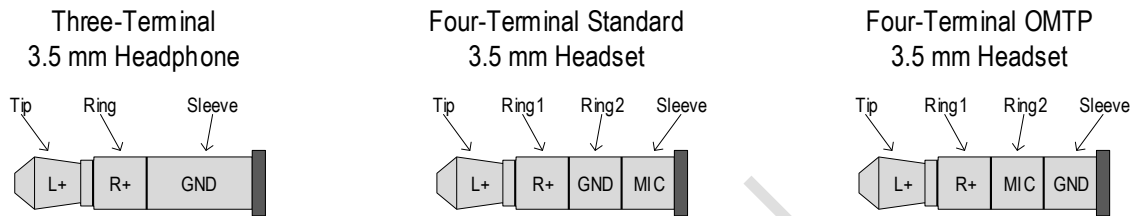

Figure 6. Multi-standard headset support

2.5.1.1. Insertion Scenarios

Six main scenarios exist during insertion into a headset-capable jack—three plug types (four-terminal CTIA headset, four-terminal OMTP headsets, and three-terminal headphones), into two jack types (CTIA four-terminal and OMTP four-terminal).

For each of the main scenarios, two sub-scenarios exist—an intermediate state during insertion where the plug is 3/4-inserted into the jack (the terminals are shifted by one). This intermediate state, due to the design of typical four-terminal jacks, could potentially last several seconds.

- The CTIA headset is plugged into the CTIA jack
- The OMTP headset is plugged into the OMTP jack
- The CTIA headset is plugged into the OMTP jack
- The OMTP headset is plugged into the CTIA jack
- The normal headphone (three-terminal plug) is plugged into the CTIA jack
- The normal headphone (three-terminal plug) is plugged into the OMTP jack

The detection circuitry is triggered as a plug is inserted into the headset jack, which is achieved by the presence signal from the jack sense state machine. In all scenarios, the jack sense terminal can trigger jack sense when the plug is only 3/4 inserted. Because the plug can be held in this position, it is possible that jack sense can be triggered several seconds before the plug is fully inserted.

2.5.2. Jack Detect

The jack sensing circuit is used to detect the state of an off-chip resistor divider, whose value depends on which jacks are connected. This circuit is structured as a 4-bit successive approximation ADC, using an internal resistor-ladder DAC to mimic the external ladder, and a comparator that compares the external voltage versus the DAC voltage.

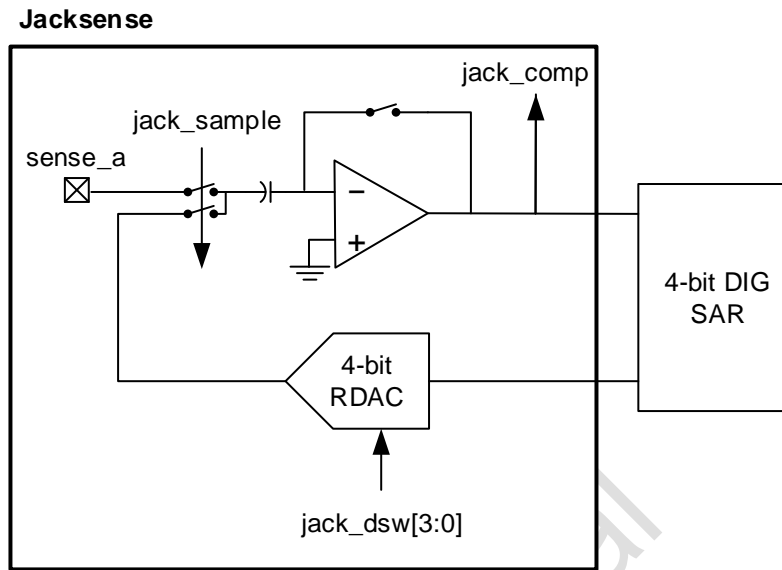

Figure 7. Jack sensing

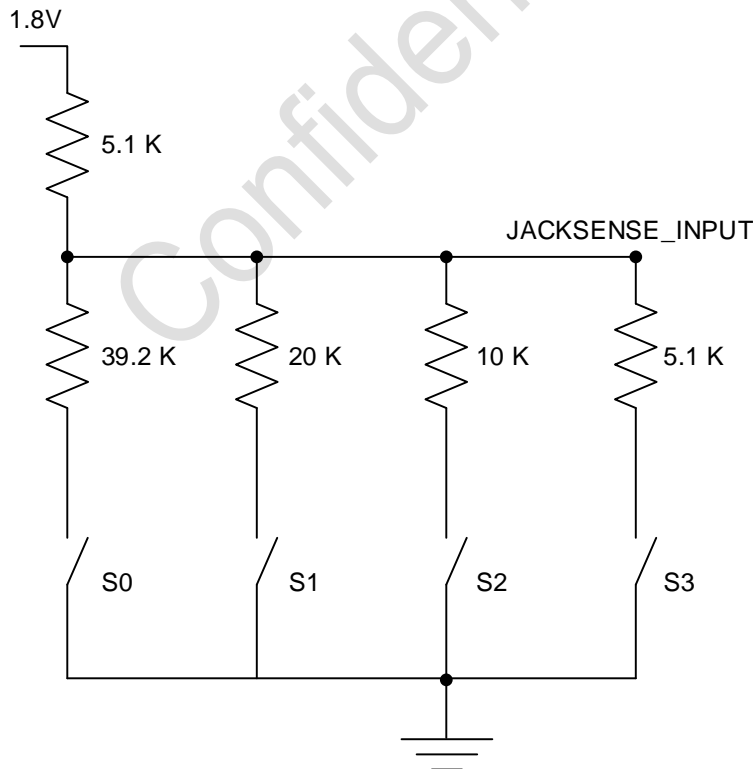

Figure 8. External circuit

2.5.3. Microphone Button Detect (Android Wired Audio Headset Specification)

The CX21986 includes support for a four-button interface using the microphone signal as defined in the *Android Wired Audio Headset Specification* (<http://source.android.com/accessories/headset-spec.html>)

The microphone itself is modeled as a $1\text{k}\Omega$ or greater resistor. This is a reasonable model for common ECM microphones used in PCs and headsets. The CODEC is expected to provide a micbias voltage between 2.75V and 2.96V for compatibility with common microphones.

Each button has a unique resistance that is placed in parallel with the microphone when the button is pressed.

Table 102. Microphone button detect

Resistor	Minimum	Nominal	Maximum
Microphone	$1\text{ k}\Omega$	—	—
Button 1	0	1	$70\ \Omega$
Button 2	$210\ \Omega$	$240\ \Omega$	$290\ \Omega$
Button 3	$360\ \Omega$	$470\ \Omega$	$680\ \Omega$
Button 4	$110\ \Omega$	$135\ \Omega$	$180\ \Omega$

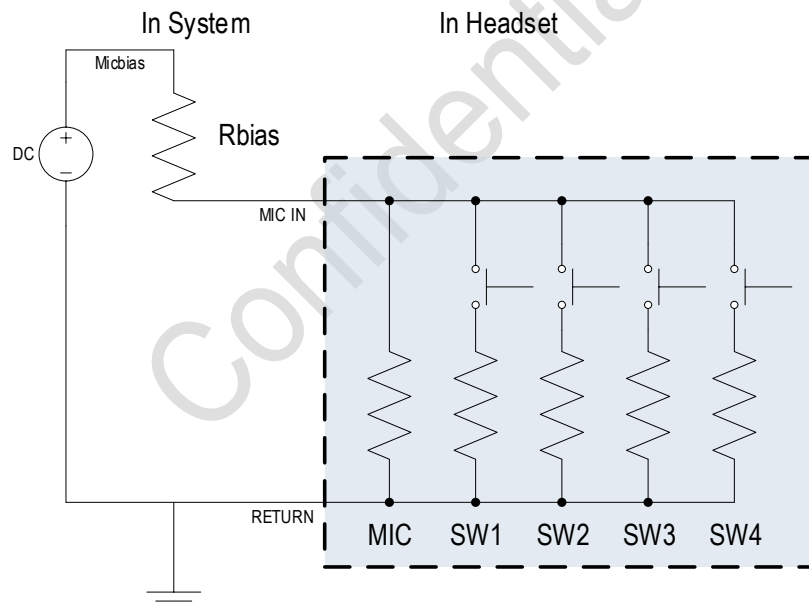

Figure 9. Microphone button detect

Button detection has an independent enable and several other controls. The initial detection of a button press requires a minimum load to avoid unintended events due to loud noises or microphones with large quiescent currents. The minimum load required to start a button detection cycle may be set to (values are approximate):

- $1\text{ k}\Omega$
- $1.7\text{ k}\Omega$
- $200\ \Omega$
- $500\ \Omega$

Because the button detection process measures the voltage at the microphone input in the presence of audio and noise, the ADC output is filtered before it is evaluated. The result is compared to a set of thresholds to determine which button (if any) was pressed. This result is further tested for stability before any action is taken.

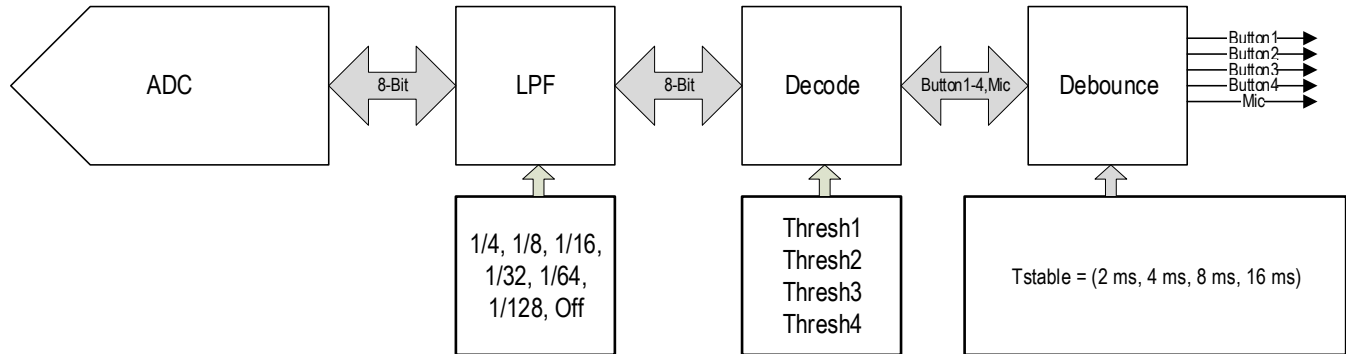

Figure 10. ADC clocked at 768 kHz

The ADC is clocked at 768 kHz for an effective sample rate of 48 kHz. This ADC is usually powered down until button detection is enabled, a headset is detected, and a button press is suspected. This is determined by monitoring the micbias detect signal when the headset detection state machine has determined that a headset has been inserted. This signal is filtered with the same settings as used during the headset detection process.

The raw ADC data is passed through a simple programmable single pole LPF. This filter has a minimum of four settings to adjust the response as needed. The filtered ADC output is then compared to four programmable 8-bit thresholds that determine which button is pressed:

- Button 1 threshold = An ADC value below this value is decoded as a B1 press
- Button 2 threshold = An ADC value below this value and greater than or equal to the button 1 threshold is decoded as a B2 press
- Button 3 threshold = An ADC value below this value and greater than or equal to the button 2 threshold is decoded as a B3 press
- Button 4 threshold = An ADC value below this value and greater than or equal to the button 3 threshold is decoded as a B4 press
- An ADC value equal to or above the button 4 threshold is decoded as MIC only—no buttons were pressed

The output from the button decoder is further filtered to reject the switch contact bounce and other issues. If the output from the decoder remains the same for the Tstable time (programmable with at least four values), then the value is considered valid.

In addition, a programmable long press counter (adjustable) is used to distinguish between a short and long press. The suggested timer values are 0.25s, 0.5s, 0.75s, 1s, 1.5s, 2s, 3s, and 4s.

The button status is available in a dedicated register with at least the following information:

- LP = Long press is detected
- MIC = Impedance was above the valid range for the buttons
- B4 = Button 4 was detected
- B3 = Button 3 was detected
- B2 = Button 2 was detected
- B1 = Button 1 was detected
- UP = A complete button press/release cycle has occurred
- DN = A button press has been detected, but the button may not have been released

2.6. Control Signals

The CX21986 supports I²C, UART, and USB HID interfaces for serial communications with the CX21986 registers for command and control.

2.6.1. I²C Configuration

Configure the following CX21986 pins for I²C operations (read or write):

- I2C_SPI_SCL = I²C clock
- I2C_SDA = I²C bidirectional serial data

2.6.1.1. I²C Write Operation

Complete the following steps for a host writing to the slave CX21986 device.

1. Send a start sequence.
2. Send the I²C address of the slave with the R/W bit low.
3. Send the internal register address you want to write to, and then send the high byte followed by the low byte.
4. Send the data byte.
5. Optional: Send any further data bytes—burst operation.
6. Send the stop sequence.

Write Single Location

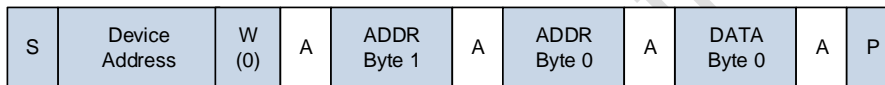

Write Auto Increment

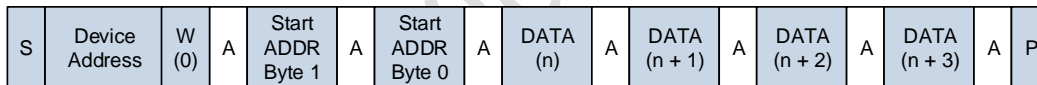

Figure 11. I²C write operations

2.6.1.2. I²C Read Operation

Complete the following steps for a host reading from the slave CX21986 device.

1. Send a start sequence.
2. Send the I²C address with the R/W bit low.
3. Send the internal register address you want to read, and then send the high byte followed by the low byte.
4. Send a start sequence again (repeated start).
5. Send the I²C address with the R/W bit high.
6. Read the data byte.
7. Optional: Send any further data bytes—Burst operation.
8. Send the stop sequence.

Read Single Location

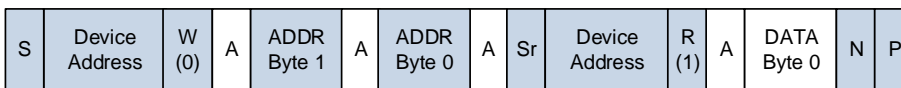

Read Auto Increment

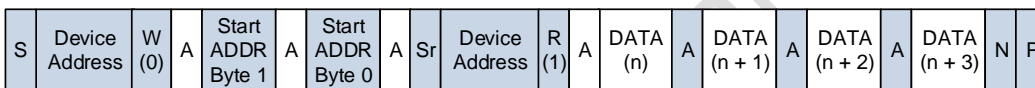

Read Continuing Auto Increment

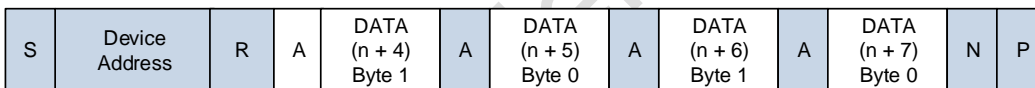

Figure 12. I²C read operations

2.6.2. UART

The UART is a serial communication device that communicates with the CX21986 registers. The pins are UART_RX, UART_TX, and the GPIO0, which also serve as the CTS. The UART operates at 115,200 bps, no parity bit, 8 data bits, and 1 stop bit. For a file transfer, the CTS should always be used to prevent a UART buffer overflow.

2.6.3. Button Matrix

Each button in the keypad matrix returns a key value 0x0–0xF. This key value is matched to an action table, and the corresponding action is executed when the key is pressed. Any key function can be mapped to any key by changing the value in the BUTTON_DEFAULTS table, located from 0x50–0x5F. The table keypad value matrix in Table 103 shows the KSOUT and KSIN lines.

Table 103. Button matrix

	KSOUT4	KSOUT5
KSIN3	1	5
KSIN2	2	6
KSIN1	3	7
KSIN0	4	8

2.6.4. Read Key Value

Multi-press key combinations are supported on KSOUT4 and KSOUT5 and return a key with the value 0x9–0xE. All other multi-press key combinations are ignored and return 0x00 or no button.

Table 104. Read key value

	KSOUT4	KSOUT5
KSIN3-KSIN2	9	C
KSIN2-KSIN1	A	D
KSIN1-KSIN0	—	—

When using the device in HS microphone mode (Host [2]=1), Google-style multi-button detection using the micbias can be used. The Google style micbias buttons map to keys 5, 6, 7, and 8.

Note: The multi-key press is not supported with the micbias buttons.

The table default is:

BUTTON_DEFAULTS: ;button location assignment variables. map buttons to specific functions.

```
.DB $00 ;50 NoButton ;KPS5 -----
.DB $01 ;51 Buttn1 ;KPS4 |
.DB $02 ;52 Buttn2 ; | |
.DB $03 ;53 Buttn3 ; -----
.DB $04 ;54 SPKMuteButtn ;KPR3- 01 | 05 | ;Multi Keypress
.DB $05 ;55 VOLUPButtn ; ----- ;1-2 = 9
.DB $06 ;56 VOLDNButtn ;KPR2- 02 | 06 | ;2-3 = A
.DB $07 ;57 MicMuteButtn ; ----- ;3-4 = B
.DB $08 ;58 HookButtn ;KPR1- 03 | 07 | ;5-6 = C
.DB $09 ;59 Multi button 1-2 ; ----- ;6-7 = D
.DB $0A ;5A Multi button 2-3 ;KPR0- 04 | 08 | ;7-8 = E
.DB $0B ;5B Multi button 3-4 ; -----
.DB $0C ;5C Multi button 5-6
.DB $0D ;5D Multi button 6-7
.DB $0E ;5E Multi button 7-8
.DB $0F ;5F N/A
```

This table maps a telephone keypad that looks like:

KSIN3	KSOUT4	KSOUT5
KSIN2	Button1	VOLUP
KSIN1	Button2	VOLDN
KSIN0	Button3	MicMute
	SPKMute	Hook

3. Power Management

The CX21986 incorporates an internal charge pump (CP) and LDOs to generate all the power supplies required by the internal circuitry, as well as external supporting functions.

3.1. Charge Pump

The internal CP generates the positive (PVDD) and (MVDD) supplies required by the headphone driver. The CP takes the USB supply (3V to 5.5V) as input and generates PVDD (1.8V) and MVDD (-1.7V) voltages. To minimize power consumption, the charge pump can also power the core LDO, which is used for supplying digital core functions.

The CP is designed with short circuit protection as well as in-rush current limit functions to comply with USB in-rush current specifications.

3.2. Reference Voltages

The CX21986 incorporates built-in circuits for providing accurate reference voltages to all LDOs, charge pumps, ADCs and DACs.

3.3. LDOs

The CX21986 consists of three LDOs:

- 3.3V LDO for digital I/O
- 1.8V for analog circuitry
- 1.25V for digital core functions

The LDOs are designed with short circuit protection as well as in-rush current limit functions to comply with USB in-rush current specifications.

3.4. Wake-Up Sources

The CX21986 can be taken out of low power suspend mode by three sources:

- USB
- Button push
- Jack plug-in

4. On-Chip Reference Clock Generation

The internal reference clock (IRC) generator provides a stable 48 MHz clock using a 1 kHz source derived from USB start of frame (SOF) packets as a reference. The IRC output is provided as the reference clock to the PLL frequency synthesizer to generate the required audio master clock.

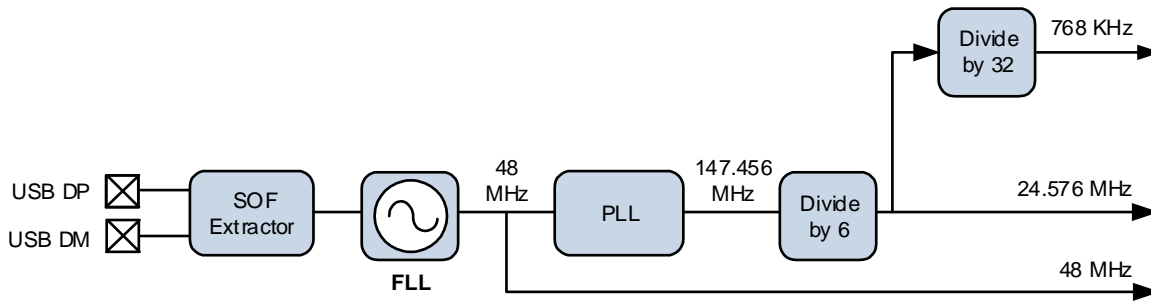

Figure 13. On-chip reference clock generation

Confidential

5. Synaptics Hum Noise Cancellation Technology

When a docking station is connected to powered speakers, and is in a sleep or power-down mode, hum noise occurs. The hum noise at the headphone output is caused by improper grounding.

The CX21986 hum noise cancellation IP incorporates internal circuitry to eliminate hum noise when the device is unpowered.

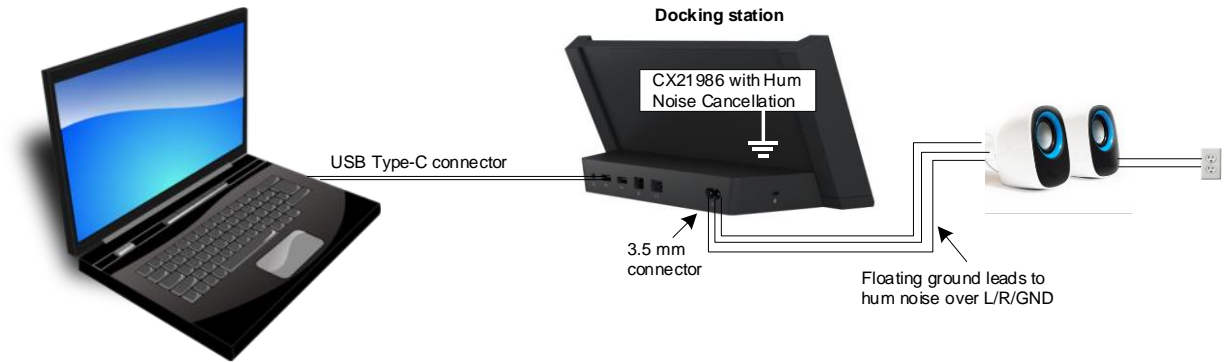

Figure 14. Synaptics hum noise cancellation technology

6. Application Diagrams

6.1. USB Type-C Docking Station and Audio Adapter

The CX21986 provides a high-quality, low-cost audio solution for USB docking stations and audio adapters. An audio adapter is simply a single dongle that plugs into a USB Type-C port and allows the user to plug in their legacy 3.5 mm headset. The CX21986 allows for the use of analog or digital microphones. Single or dual microphones are also supported. The capless stereo output port supports both headphones or external powered speakers. Further, the device can auto-switch between CTIA and OMTP-style headphones and detect whether or not a microphone is available. Multiple GPIO pins are available for button and LED support. Input power of 3.0V to 5.5V is required, and all other supplies are generated internally. The CX21986 also allows for powering external 3.3V circuitry, with the ability to deliver up to 90 mA of current.

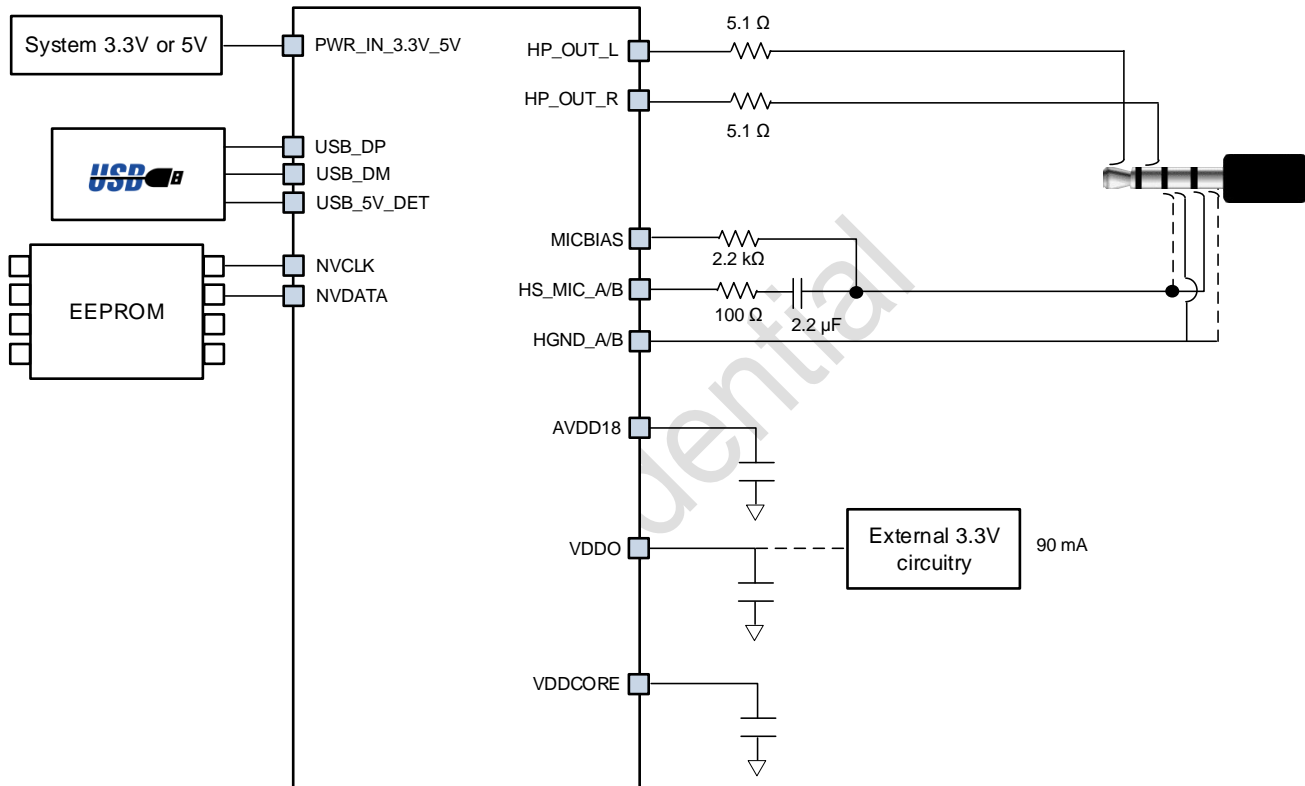

Figure 15. USB Type-C audio adapter docking station and audio adapter block diagram

6.2. USB Type-C Headset with Android Button Support

The CX21986 provides a high-quality, low-cost solution for wired USB headsets used with smart phones or PCs. The CX21986 allows for the use of analog or digital microphones. Single or dual microphones are also supported. The capless stereo output port supports all headphones with an impedance of 16Ω or greater. Multiple GPIO pins are available for button and LED support. Input power of 3.0V to 5.5V is required, and all other supplies are generated internally. The CX21986 also allows for powering external 3.3V circuitry, with the ability to deliver up to 90 mA of current.

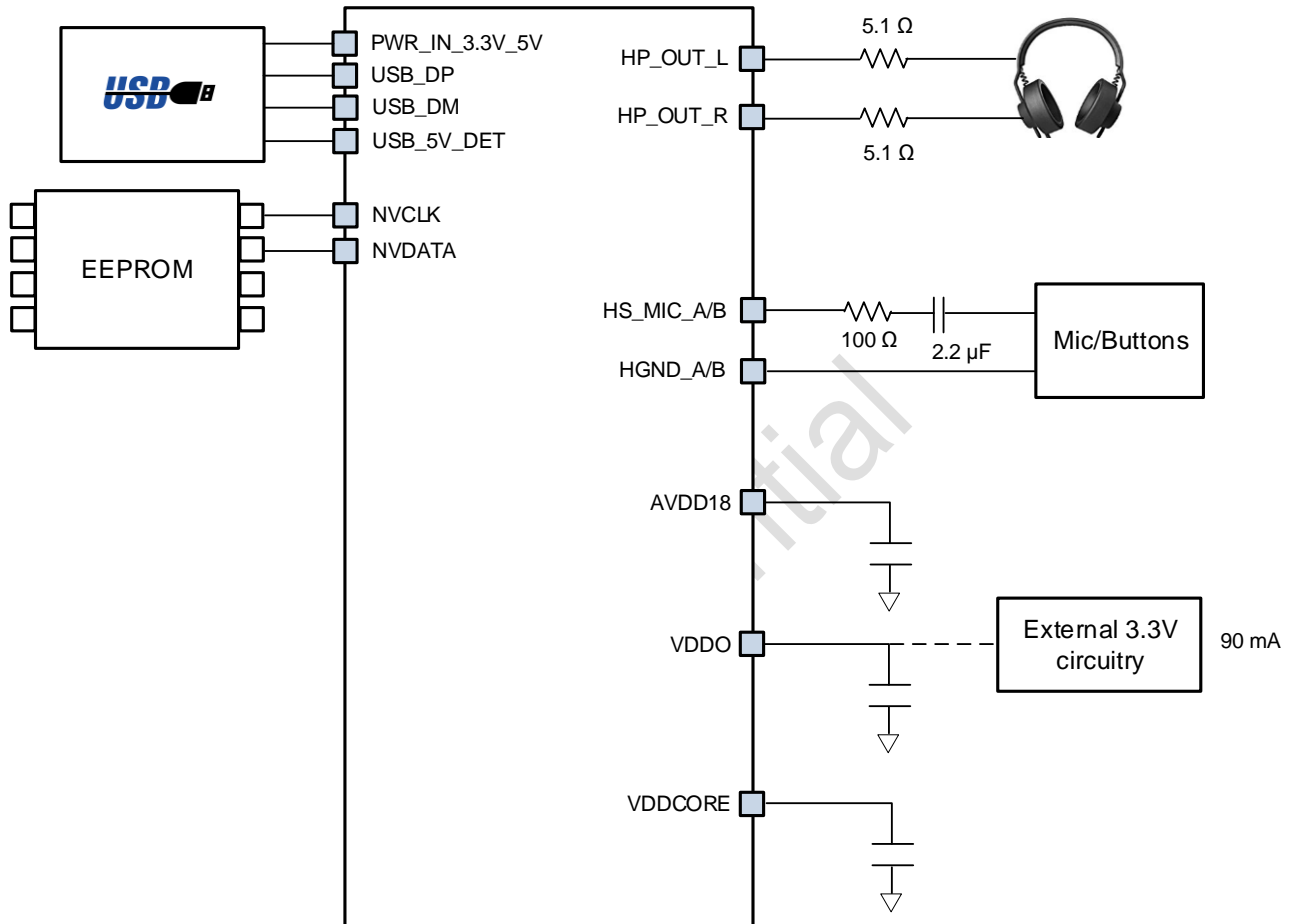

Figure 16. USB Type-C headset with android button support block diagram

7. Electrical Characteristics

Table 105. DC supply voltages

Parameter	Symbol	Minimum	Typical	Maximum	Units	Notes
Analog/Digital Power Supply	V5ANA/DIG	3.0	5	5.5	V	—
Analog Power	AVDD	1.7	1.8	2.0	V	—
Charge Pump Power	PVDD	1.76	1.9	2.0	V	—
	MVDD	-1.47	-1.61	-1.75		MVDD is shut off in idle mode.
Digital 3.3V I/O Supply	VDDO	3.0	3.3	3.6	V	This power rail can also source external circuitry with a maximum current of 90 mA.
Digital Core Supply	VDD, VDD_CORE	1.24	1.3	1.4	V	—
VREF	VREF	1.08	1.2	1.32	V	VREF is shut off in idle mode.

Table 106. DC characteristics—TTL compatible (GPIOs and keypad interface)

Parameter	Symbol	Minimum	Typical	Maximum	Units	Notes
Input Voltage Low	V_{IL}	-0.5	—	0.8	V	—
Input Voltage High	V_{IH}	2	—	Vdd+0.5	V	—
Output Voltage Low	V_{OL}	0	—	0.4	V	—
Output Voltage High	V_{OH}	2.4	—	Vdd	V	—
GPIO Output Sink Current at 0.4V Maximum	—	—	—	12	mA	—
GPIO Output Source Current at 2.97V Minimum	—	—	—	12	mA	—
GPIO Rise/fall Time	—	—	—	4	ns	25% to 75%.

Note: Test conditions unless otherwise stated:

- VDDO=3.3 + 0.3 VDC
- TA = 0 °C to 70 °C
- External load = 50 pF

Table 107. DAC performance (32 Ω load)

Parameter	Minimum	Typical	Maximum	Units	Comments
Dynamic Range 48 kHz, 24-bit	—	-103	—	dBFS	A-weighted, 20 Hz to 20 kHz. -60 dBFS
Dynamic Range 96 kHz, 24-bit	—	-103	—	dBFS	A-weighted, 20 Hz to 20 kHz. -60 dBFS
Dynamic Range 192 kHz, 16-bit	—	-97	—	dBFS	A-weighted, 20 Hz to 20 kHz. -60 dBFS
THD+N 48 kHz, 24-bit	—	-87	—	dBFS	20 Hz to 20 kHz into 32 Ω . -3 dBFS
THD+N 96 kHz, 24-bit	—	-87	—	dBFS	20 Hz to 20 kHz into 32 Ω . -3 dBFS
THD+N 192 kHz, 16-bit	—	-87	—	dBFS	20 Hz to 20 kHz into 32 Ω . -3 dBFS
Crosstalk	—	-81	—	dB	HGND series resistance = 0 Ω
Crosstalk	—	-76	—	dB	HGND series resistance = 1 Ω

Table 108. DAC performance (10 k Ω load)

Parameter	Minimum	Typical	Maximum	Units	Comments
Dynamic Range 48 kHz, 24-bit	—	-102	—	dBFS	A-weighted, 20 Hz to 20 kHz. -60 dBFS
Dynamic Range 96 kHz, 24-bit	—	-102	—	dBFS	A-weighted, 20 Hz to 20 kHz. -60 dBFS
Dynamic Range 192 kHz, 16-bit	—	-97	—	dBFS	A-weighted, 20 Hz to 20 kHz. -60 dBFS
THD+N 48 kHz, 24-bit	—	-88	—	dBFS	20 Hz to 20 kHz into 10 k Ω . -3 dBFS
THD+N 96 kHz, 24-bit	—	-88	—	dBFS	20 Hz to 20 kHz into 10 k Ω . -3 dBFS
THD+N 192 kHz, 16-bit	—	-88	—	dBFS	20 Hz to 20 kHz into 10 k Ω . -3 dBFS
Crosstalk	—	-81	—	dB	—

Table 109. ADC performance (headset microphone)

Parameter	Minimum	Typical	Maximum	Units	Comments
Dynamic Range Microphone Boost = 0 dB	—	-97	—	dBFS	A-weighted, 20 Hz to 20 kHz, -60 dBFS. 48 kHz, 24-bit
Dynamic Range Microphone Boost = 12 dB	—	-96	—	dBFS	A-weighted, 20 Hz to 20 kHz, -60 dBFS. 48 kHz, 24-bit
Dynamic Range Microphone Boost = 24 dB	—	-88	—	dBFS	A-weighted, 20 Hz to 20 kHz, -60 dBFS. 48 kHz, 24-bit
Dynamic Range Microphone Boost = 36 dB	—	-77	—	dBFS	A-weighted, 20 Hz to 20 kHz, -60 dBFS. 48 kHz, 24-bit
Dynamic Range Microphone Boost = 0 dB	—	-91	—	dBFS	A-weighted, 20 Hz to 20kHz, -60 dBFS. 48 kHz, 16-bit
Dynamic Range Microphone Boost = 12 dB	—	-91	—	dBFS	A-weighted, 20 Hz to 20 kHz, -60 dBFS. 48 kHz, 16-bit
Dynamic Range Microphone Boost = 24 dB	—	-87	—	dBFS	A-weighted, 20 Hz to 20 kHz, -60 dBFS. 48 kHz, 16-bit
Dynamic Range Microphone Boost = 36 dB	—	-77	—	dBFS	A-weighted, 20 Hz to 20 kHz, -60 dBFS. 48 kHz, 16-bit
THD+N Mic boost = 0 dB	—	-86	—	dBFS	20 Hz to 20 kHz, -3 dBFS. 48 kHz, 16-bit
THD+N Microphone Boost = 12 dB	—	-86	—	dBFS	20 Hz to 20 kHz, -3 dBFS. 48 kHz, 16-bit
THD+N Microphone Boost = 24 dB	—	-83	—	dBFS	20 Hz to 20 kHz, -3 dBFS. 48 kHz, 16-bit
THD+N Microphone Boost = 36 dB	—	-74	—	dBFS	20 Hz to 20 kHz, -3 dBFS. 48 kHz, 16-bit

8. Pin Descriptions

8.1. 43-Pin WLCSP Hardware Interface Signals

Figure 17 shows the CX21986 43-pin WLCSP device signals by major interface.

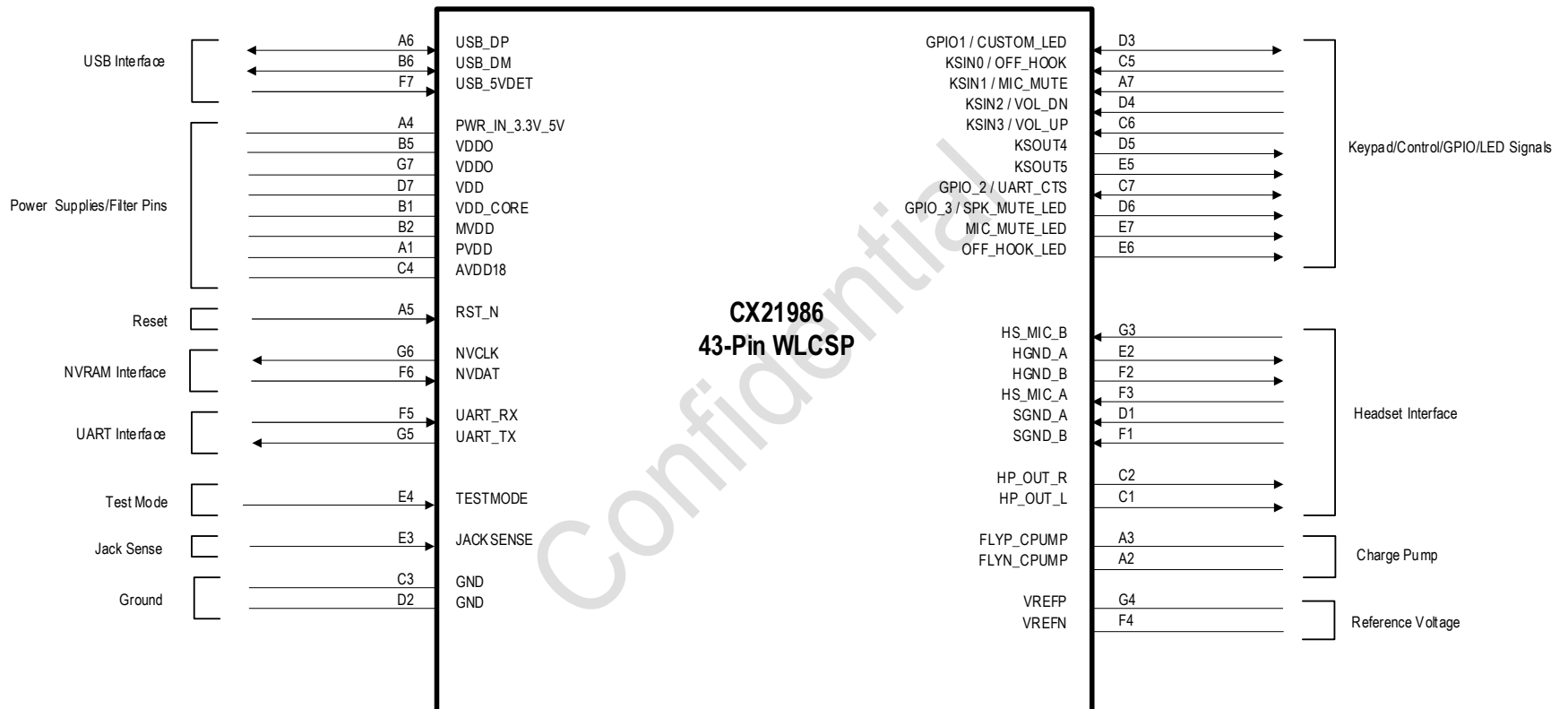

Figure 17. CX21986 43-pin WLCSP hardware interface signals

8.2. 43-Pin WLCSP Pin Signals

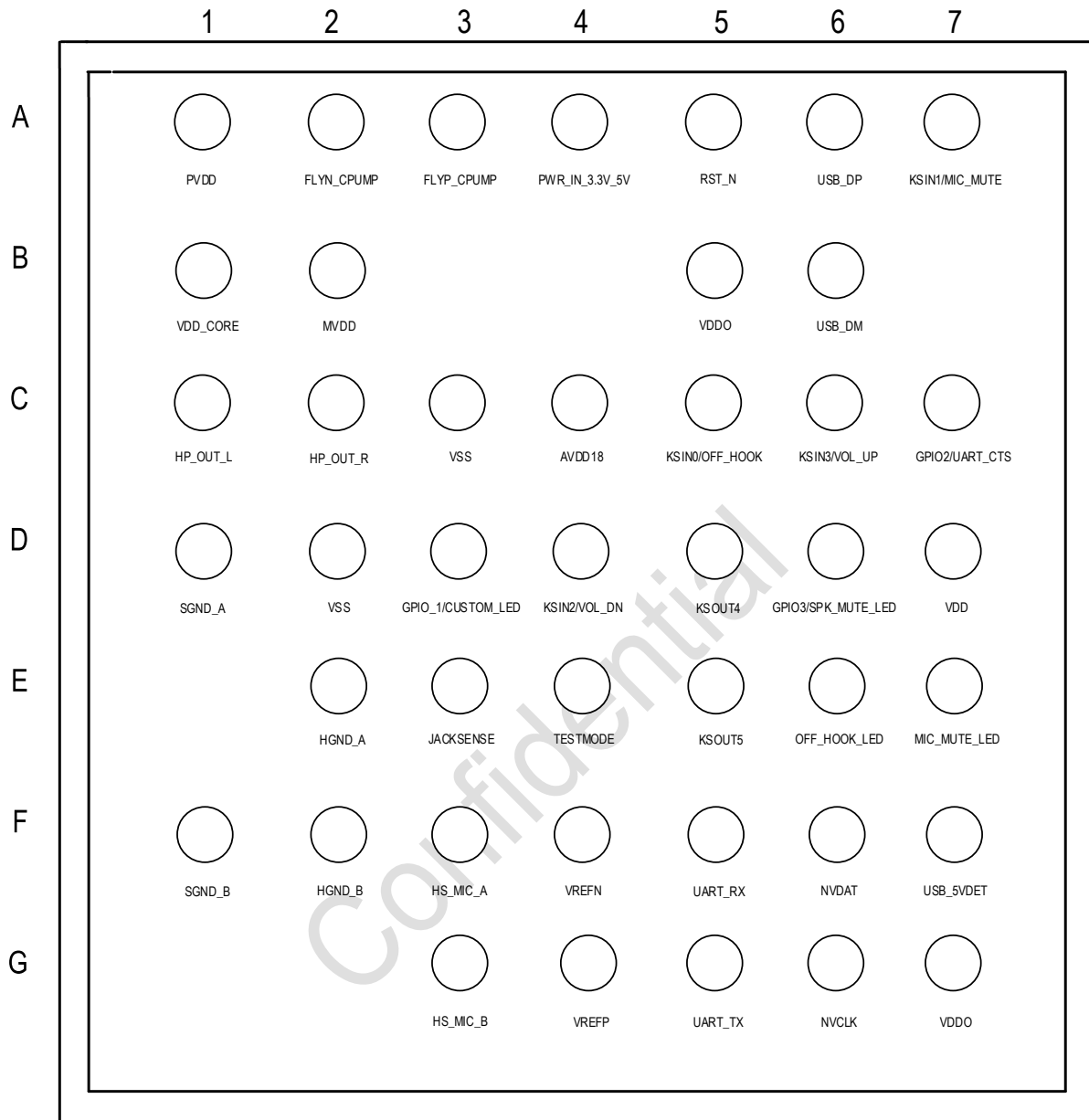

Figure 18. CX21986 43-pin WLCSP pin signals

8.3. Pin Assignments

Table 110. Pin assignments

Pin	Pin Name
A1	PVDD
A2	FLYN_CPUMP
A3	FLYP_CPUMP
A4	PWR_IN_3.3V_5V
A5	RST_N
A6	USB_DP
A7	KSIN1/MIC_MUTE
B1	VDD_CORE
B2	MVDD
B3	(NO BALL)
B4	(NO BALL)
B5	VDDO
B6	USB_DM
B7	(NO BALL)
C1	HP_OUT_L
C2	HP_OUT_R
C3	VSS
C4	AVDD18
C5	KSIN0/OFF_HOOK
C6	KSIN3/VOL_UP
C7	GPIO2/UART_CTS
D1	SGND_A
D2	VSS
D3	GPIO1/CUSTOM_LED
D4	KSIN2/VOL_DN

Pin	Pin Name
D5	KSOUT4
D6	GPIO3/SPK_MUTE_LED
D7	VDD
E1	(NO BALL)
E2	HGND_A
E3	JACKSENSE
E4	TESTMODE
E5	KSOUT5
E6	OFF_HOOK_LED
E7	MIC_MUTE_LED
F1	SGND_B
F2	HGND_B
F3	HS_MIC_A
F4	VREFN
F5	UART_RX
F6	NVDAT
F7	USB_5VDET
G1	(NO BALL)
G2	(NO BALL)
G3	HS_MIC_B
G4	VREFP
G5	UART_TX
G6	NVCLK
G7	VDDO

8.4. Hardware Signal Definitions

Table 111. Hardware signal definitions

Label	Pin	I/O Type	Signal Name	Description
USB Signals				
USB_DP	A6	Digital In	USB Data Plus	—
USB_DM	B6	Digital In	USB Data Minus	—
Control Signals				
RST_N	A5	Digital In	Reset	Active low input asserted to initialize registers, sequencers, and signals to a consistent reset state.
MIC_MUTE_LED	E7	Digital Out	MIC_MUTE_LED	Turns the external LED on when the microphone mute button is pushed. Connect to an anode of the LED.
TEST MODE	E4	Digital In	TEST	Connect to ground through a 0Ω resistor. Include the test point on this pin for one-time-programmable, non-volatile memory programming.
USB_5V_DET	F7	Digital In	5V_USB_DETECT	Connect this pin to the USB 5V through the external resistor divider.
OFF_HOOK_LED	E6	Digital Out	Turns on the External LED upon the Phone Going Off-hook.	Connect to the anode of the LED.
GPIO_1/CUSTOM_LED	D3	Digital I/O	GPIO or Custom LED Driver	Connect to the anode of the LED.
GPIO3/SPK_MUTE_LED	D6	Digital I/O	GPIO_3/SPK_MUTE_LED	. Turns the external LED on when the Playback Mute button is pushed. Connect to an anode of the LED. This pin can also be programmed as GPIO.
Keypad Signals				
KSIN[0:3]	C5, A7, D4, C6	Digital In	Keypad Scan Inputs	Assignment for the following standard four buttons: <ul style="list-style-type: none"> • KSIN0 = Off-hook • KSIN1 = Microphone Mute • KSIN2 = Volume Down • KSIN3 = Volume Up
KSOUT4, KSOUT5	D5, E5	Digital Out	Keypad Scan Output	Outputs a strobe signal as part of the process to detect if the Volume Up, Volume Down, Microphone Mute, or Playback Mute buttons have been pushed.
NVRAM Signals				
NVCLK	G6	Digital Out	NVRAM Clock	Connects to the clock pin of the external EEPROM.
NVDATA	F6	Digital I/O	NVRAM Data	Connects to the data pin of the external EEPROM.
UART Interface				
UART_TX	G5	Digital Out	UART Serial Transmission Data	—
UART_RX	F5	Digital In	UART Serial Receiving Data	—
GPIO_2/UART_CTS	C7	Digital Out	GPIO or UART Clear-To-Send (CTS)	—

Label	Pin	I/O Type	Signal Name	Description
Jack Sense				
JACKSENSE	E3	Analog In	Jack Sense	Connect to the external resistor network to sense up to four jacks.
Charge Pump (CP)				
PVDD	A1	Power	CP Positive Power Supply	Internally generated positive CP power. Connect to 10 μ F and 0.1 μ F external filtering.
FLYP_CPUMP	A3	Power	CP Positive Transfer Charge	Connect to CPUMP_FLYN through a 2.2 μ F capacitor.
FLYN_CPUMP	A2	Power	CP Negative Transfer Charge	Connect to CPUMP_FLYP through a 2.2 μ F capacitor.
MVDD	B2	Power	CP Negative Power Supply	Internally generated negative CP power. Connect to 2.2 μ F and 0.1 μ F external filtering.
Reference Voltage				
VREFP	G4	Power	VREFP—Internally Generated Supply	Connect to 0.1 μ F and 1.0 μ F to VREFN.
VREFN	F4	Power		Connect to analog ground (AGND).
Microphone and Headphone Interfaces				
HS_MIC_B	G3	Analog Input	Headset Microphone Input	Mono microphone input for OMTP-style headsets.
HS_MIC_A	F3	Analog Input	Headset Microphone Input	Mono microphone input for CTIA-style headsets.
HGND_B	F2	GND/Micbias	Headset Microphone Ground	Microphone: <ul style="list-style-type: none"> • Ground terminal for OMTP-style headsets • Bias for CTIA-style headsets Note: 2.75V and 2.96 micbias are applicable.
HGND_A	E2	GND/Micbias	Headset Microphone Ground	Microphone: <ul style="list-style-type: none"> • Ground terminal for CTIA-style headsets • Bias for OMTP-style headsets Note: 2.75V and 2.96 micbias are applicable.
HP_OUT_L	C1	Analog Out	Left Headphone	—
HP_OUT_R	C2	Analog Out	Right Headphone	—
SGND_A	D1	Analog Input	Headset Sense Pin	—
SGND_B	F1	Analog Input	Headset Sense Pin	—

Label	Pin	I/O Type	Signal Name	Description
Power Supplies				
VDDO	B5, G7	Digital I/O Power	3.3V I/O Supply	Connect to 2.2 μ F and 2 x 0.1 μ F to GND.
VDD_CORE	B1	Digital Power Output	Digital Supply for Core Logic	Connect 0.1 μ F and 2.2 μ F to GND.
VDD	D7	Digital Power Input	Digital Supply	Connect 0.1 μ F to GND.
AVDD18	C4	Analog power	1.8V Analog Supply	Connect 2.2 μ F and 0.1 μ F to AGND.
PWR_IN_3.3V_5V	A4	Analog/Digital Power	3.3V or 5V Analog/Digital Input Power Supply	Connect 0.1 μ F and 4.7 μ F to GND.
Ground Signal				
VSS	D2, C3	Power	Ground	—

Confidential

9. Power Consumption

Table 112. Power consumption

Parameters	Minimum	Typical	Maximum	Units	Comments
USB Suspend w/o remote wakeup	—	0.88	—	mA	—
USB Suspend with remote wakeup and headphone plugged in	—	0.89	—	mA	—
USB Suspend with remote wakeup and headset plugged in	—	1.29	—	mA	—
Idle	—	12.14	—	mA	Powered on, playback, and record are not active
Headphone Active, Playing Silence	—	17.23	—	mA	Headphone load = 32 Ω
Headphone Active, Output Level = (0.1 mW), playing out 16-bit, 48 kHz sample rate, 997 Hz tone.	—	18.75	—	mA	Headphone load = 32 Ω
	—		—		
Headphone Active, Output Level = (0.1 mW), playing out 24-bit, 96 kHz sample rate, 997 Hz tone.	—	19.51	—	mA	Headphone load = 32 Ω
	—		—		
Headphone Active, Output Level = (0.1 mW), playing out 16-bit, 192 kHz sample rate, 997 Hz tone.	—	20.76	—	mA	Headphone load = 32 Ω
Headphone Active, Output Level = (0.5 mW), playing out 16-bit, 48 kHz sample rate, 997 Hz tone.	—	20.72	—	mA	Headphone load = 32 Ω
Headphone Active, Output Level = (0.5 mW), playing out 24-bit, 96 kHz sample rate, 997 Hz tone.	—	21.48	—	mA	Headphone load = 32 Ω
Headphone Active, Output Level = (0.5 mW), playing out 16-bit, 192 kHz sample rate, 997 Hz tone.	—	22.75	—	mA	Headphone load = 32 Ω
Headphone Active, Output Level = (1 mW), playing out 16-bit, 48kHz sample rate, 997 Hz tone.	—	22.27	—	mA	Headphone load = 32 Ω
Headphone Active, Output Level = (1 mW), playing out 24-bit, 96 kHz sample rate, 997 Hz tone.	—	22.99	—	mA	Headphone load = 32 Ω
Headphone Active, Output Level = (1 mW), playing out 16-bit, 192 kHz sample rate, 997 Hz tone.	—	24.27	—	mA	Headphone load = 32 Ω
Record Path Active	—	16.45	—	mA	Microphone input = -36 dBV Input Boost = 36 dB
Record Path Active Headphone Active, Output Level = (1 mW), Playing out 16-bit, 48 kHz sample rate, 997 Hz tone.	—	26.74	—	mA	Microphone input = -36 dBV Input boost = 36 dB Headphone load = 32 Ω
Record Path Active Headphone Active, Output Level = (1 mW), playing out 24-bit, 96 kHz sample rate, 997 Hz tone.	—	27.34	—	mA	Microphone input = -36 dBV Input boost = 36 dB Headphone load = 32 Ω .

Note: Input power = 5.0V

10. Package Dimensions and Thermal Specifications

Top View (Input)

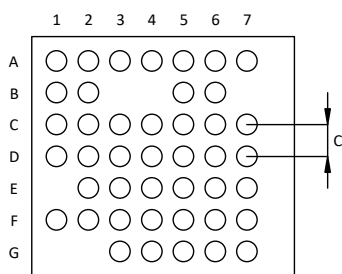

46 Solder Balls

Bottom View (Ball side up)

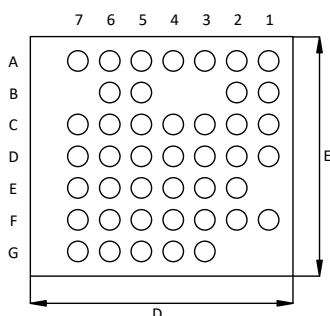

Top View (Ball side down)

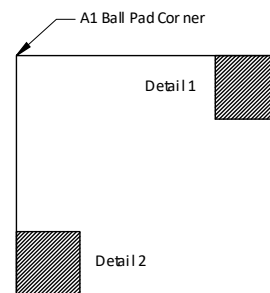

Detail 1

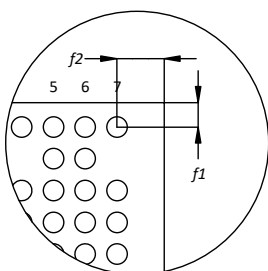

Detail 2

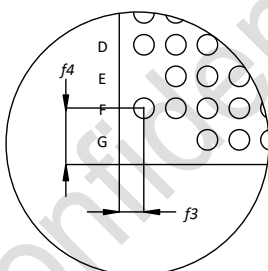

Side View

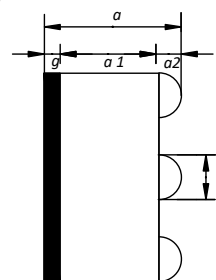

Unit : mm

Symbols	DIMENSION	
	Nominal	Tolerance
a	0.600	
a 1	0.367	± 0.015
a 2	0.208	± 0.015
C	0.400	
D	3.308	± 0.025
E	3.020	± 0.025
f 1	0.310	
f 2	0.598	
f 3	0.310	
f 4	0.710	
B	0.025	± 0.003
s	0.260	± 20%

Remarks

Unless otherwise specified dimension are in millimeters

Decimal
 X.X±0.1
 X.XX±0.05
 X.XXX±0.030

Angular
 ±1°

Coplanarity Spec (after Bumping Process)

- 1) Coplanarity Criteria : Max. 0.030 mm
- 2) Sample Size : All bumps/ die, 5 dies/ wafer, 5 wafers/ lot
- 3) Method : Peak to peak
 (The tallest bump height - The shortest bump height, within die)

Figure 19. Package dimensions 43-pin WLCSP

Table 113. Thermal specifications

Parameter	Symbol	Minimum	Typical	Maximum	Units
Operating Temperature Range	T_A	-25	—	85	°C
Operating Junction Temperature	T_J	-25	—	125	°C
Thermal Resistance ^{1, 2, 3} (four layer)	θ_{JA}	—	53	—	°C/W

1. Measurements per JEDEC EIA/JESD 51. The θ_{JA} of application boards with more than four layers stay the same or improve if the PCB construction is similar to the JEDEC EIA/JESD 51 defined four-layer PCB (2S2P plus vias).
2. For a given power dissipation, die temperature can be calculated as follows: $T_J = T_A + (\text{power dissipated} \cdot \theta_{JA})$.
3. Four layer board specification: PCB Dimension 101.5 mm × 114.5 mm and 1.6 mm thick FR-4, top and bottom layer thickness 0.070 (2 oz), inner plane thickness 0.035 (1 oz).

Confidential

11. Ordering Information

Table 114. Ordering information

Part Number	Features	Package
CX21986-10Z	USB interface	43-pin WLCSP

Note: The devices are lead-free (Pb-Free) and China Restriction of Hazardous Substance (RoHS) compliant . Contact the local Synaptics sales office for advanced software options.

Confidential

12. Revision History

Revision	Description
A	Update: <ul style="list-style-type: none">• Convert document to Synaptics template• USB voltage values• Table 105. DC supply voltages• Table 111. Hardware signal definitions
B	Converted to Synaptics stylesheet. Updated f4 dimension in Figure 19. Package dimensions 43-pin WLCSF

Confidential

Copyright

Copyright © 2018 Synaptics Incorporated. All Rights Reserved

Trademarks

Synaptics; the Synaptics logo, and AudioSmart are trademarks or registered trademarks of Synaptics Incorporated in the United States and/or other countries.

All other trademarks are the properties of their respective owners.

Notice

This document contains information that is proprietary to Synaptics Incorporated ("Synaptics"). The holder of this document shall treat all information contained herein as confidential, shall use the information only for its intended purpose, and shall not duplicate, disclose, or disseminate any of this information in any manner unless Synaptics has otherwise provided express, written permission.

Use of the materials may require a license of intellectual property from a third party or from Synaptics. This document conveys no express or implied licenses to any intellectual property rights belonging to Synaptics or any other party. Synaptics may, from time to time and at its sole option, update the information contained in this document without notice.

INFORMATION CONTAINED IN THIS DOCUMENT IS PROVIDED "AS-IS," AND SYNAPTICS HEREBY DISCLAIMS ALL EXPRESS OR IMPLIED WARRANTIES, INCLUDING BUT NOT LIMITED TO ANY IMPLIED WARRANTIES OF MERCHANTABILITY AND FITNESS FOR A PARTICULAR PURPOSE, AND ANY WARRANTIES OF NON-INFRINGEMENT OF ANY INTELLECTUAL PROPERTY RIGHTS. IN NO EVENT SHALL SYNAPTICS BE LIABLE FOR ANY DIRECT, INDIRECT, INCIDENTAL, SPECIAL, PUNITIVE, OR CONSEQUENTIAL DAMAGES ARISING OUT OF OR IN CONNECTION WITH THE USE OF THE INFORMATION CONTAINED IN THIS DOCUMENT, HOWEVER CAUSED AND BASED ON ANY THEORY OF LIABILITY, WHETHER IN AN ACTION OF CONTRACT, NEGLIGENCE OR OTHER TORTIOUS ACTION, AND EVEN IF SYNAPTICS WAS ADVISED OF THE POSSIBILITY OF SUCH DAMAGE. IF A TRIBUNAL OF COMPETENT JURISDICTION DOES NOT PERMIT THE DISCLAIMER OF DIRECT DAMAGES OR ANY OTHER DAMAGES, SYNAPTICS' TOTAL CUMULATIVE LIABILITY TO ANY PARTY SHALL NOT EXCEED ONE HUNDRED U.S. DOLLARS.

Contact Us

Visit our website at www.synaptics.com to locate the Synaptics office nearest you.

